

# *HYDRAULIC CYLINDER*

## *SECTION 4*

# HYVA CYLINDER



715 04 199

Front end cylinder with outer cover

type  
equivalent to  
tipping weight  
closed length (K)

FC 129-03410-599A-K0162-1DA-HC  
FC 5.5-3-134-1DA-HC  
34-58 ton / 74-127 x1000 lbs  
157-192 mm / 6.18-7.56"

page # 1 / 2

front & side view cylinder

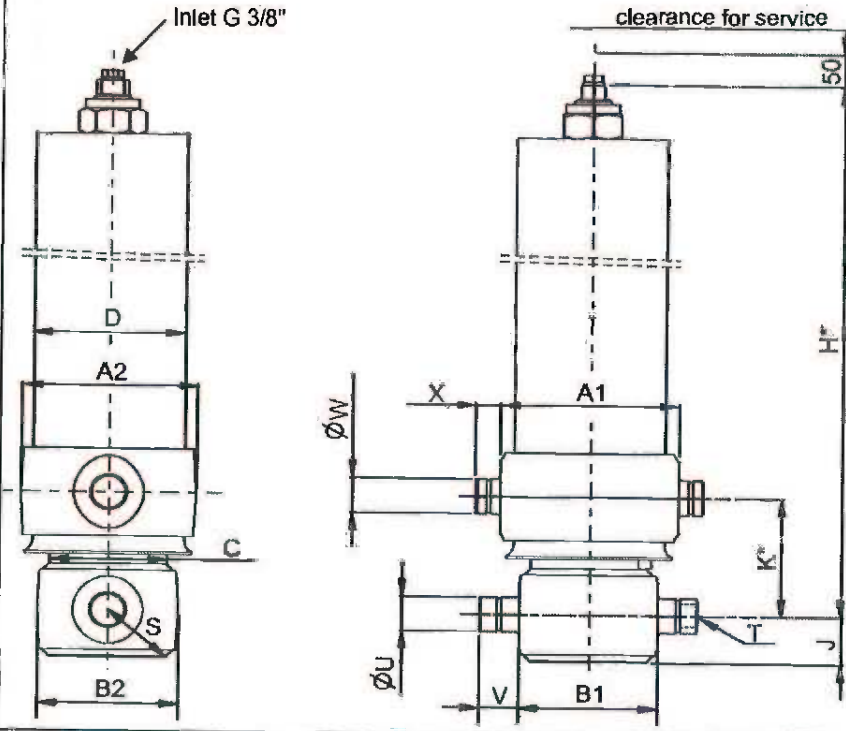

	U.S.	Metric	
	1/2	1/2	
A	9.02"/8.82"	229/224	mm
B	7.01"/7.09"	178/180	mm
C	5.87"	149	mm
D	7.68"	195	mm
E			
F			
G*			
H*	58.43"	1484	mm
I	2.56"	65	mm
J	3.59"	91	mm
K*	6.38"	162	mm
L			
M*			
N			
Q			
P			
Q			
R			
S	4.16"	106	mm
T	1 1/16"	1 1/16"	UNF
U	1.87"	47.6	mm
V	2"	50.8	mm
W	1.87"	47.6	mm
X	1.26"	32	mm
Y			
Z			

\*incl. 0.79" [-0.20"; +1.2"] pull out on pistor

## specifications

weight cylinder only	398 lbs	180 kg
total volume	10 gallon	37 L
working volume	9 gallon	34 L
maximum pressure	2756 psi	190 bar
maximum pump flow	36 gal/min	137 L/min
maximum cylinder angle to front	5 °	5 °
maximum thrust first stage**	55116 lbs	25 ton

\*\*when cyl. mounted at a large angle, thrust first stage may become too high: see Hyva Tipper Program

## technical notes

This cylinder is a lifting device only and may not be used as structural member or be subject to side load. Working pressure depends on application; never exceed maximum pressure. Cylinder painted with Akzo Air drying Enamel (RAL9005). Max duration of extension 2 hours (excluded HC). See mounting Instruction CYL-0019. See oil specification sheet OIL-0002. The smallest stage is Hard Chromed.

extension	1	2	3	4	5	6	7	8	9	total
effective diameter [Inch]	5.08	4.33	3.58							
effective diameter [mm]	129	110	91							
stroke [Inch]	44.9	45.7	43.7							134.0
stroke [mm]	1140	1160	1110							3410

## tipping weight

tipping weight at maximum pressure of 2756 psi or 190 bar and C is 7.01 inch or 178 mm

	BL	181"			171"			161"		
BL (body length);	BL	8"	16"	24"	8"	16"	24"	8"	16"	24"
OH (rear overhang);	OH	44	46	48	47	49	52	50	52	56
Ycog (vert. pos. centre of gravity);	Ycog	74	81	90	77	85	95	80	90	103
Qo (pivot length);	16"	82	91	103	86	97	113	91	105	127
C (bracket length);	28"	90	102	120	97	113		106	127	
At = stroke x 60 / Qo	39"									

Subject to change without notice.

DC-E 71504199 / 08-10-09 / RV AA

# HYVA CYLINDER



715 04 199

Front end cylinder with outer cover

type

FC 129-3-03410-599A-K0162-1DA-HC

FC 5.5-3-134-1DA-HC

page # 2 / 2

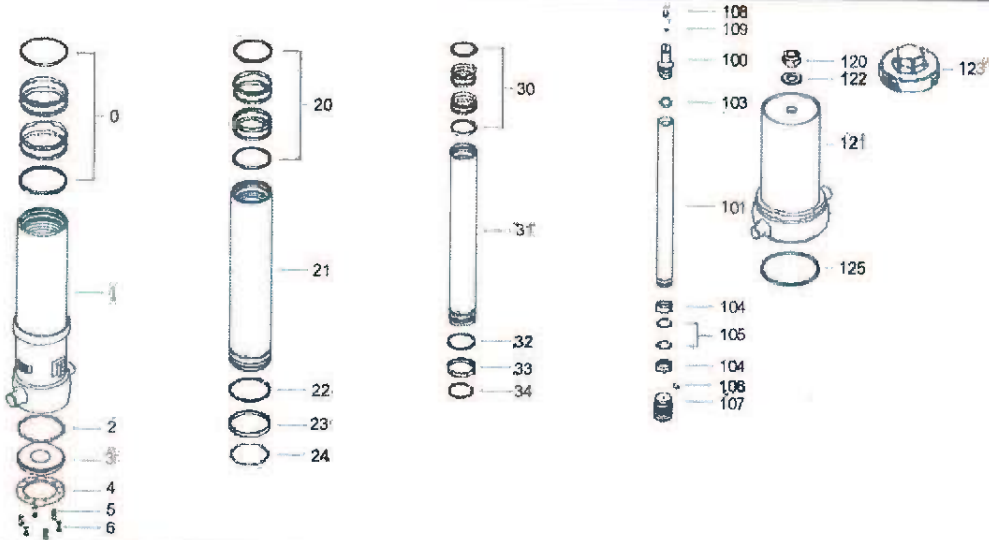

### Spare part list

Pos	Part no.	Description	Qty.
0	71802149 K	PACKSET 149	01
1	72505370R1105	BASE 149-1399-1 1/16UNF-000-90-C195.	01
2	71870030 K	SEAL BOTTOM PLATE 149	01
3	71821149	BOTTOM PLATE 149	01
4	71820149	LOCKING PLATE 149	03
5	01732559 K	SPRING WASHER M8 SET	01
6	01732055 K	BOLT M8 X 1,25 X 20 SET	01

20	71802129 K	PACKSET 129	01
21	72804371	STAGE 129-1360-HC	01
22		NOT APPLICABLE	
23	71807129 K	SLIDER 129 (2 X 1/2)	02
24	71812129 K	LIFTRING 129	01

30	71802110 K	PACKSET 110	01
31	72803373	STAGE 110-1360-HC WITHOUT OIL HOLES	01
32		NOT APPLICABLE	
33	71807110 K	SLIDER 110 (2 X 1/2)	02
34	71812110 K	LIFTRING 110	01

### Spare part list

Pos	Part no.	Description	Qty.
100	71831502	PISTON HEAD 091 WITH INLET 3/8" BSP	01
101	72402373	PISTON S 091-1288-DA-HC	01
103	71870115 K	O-RING PISTON TOP 091	01
104	71807091 K	SLIDER 091 (2 X 1/2)	02
105	71871115 K	DASHPOT RING D.091	02
106	15018308	SCREW HEX.SOCK M6X06 DIN913 FLPNT B	01
107	71871045	DASHPOT ASSEMBLY 091	01
107	71871060	DASHPOT DA PLUG M30X2	01
108	10010017	PLUG 3/8" PLASTIC	01

120	01702907	TOPNUT NYLOC M48x3 DIN 985 ZP	01
121	71704544	COVER 195-1325 PIN47	01
122	01702956	WASHER M48 DIN 125B ZP	01
123		NOT APPLICABLE	
125		NOT APPLICABLE	

### Seal kit complete:

Part no.	Description
74901430 K	Seal kit complete: consists of all packsets with packset grease, O-rings and Pin (pos.102)

When replacing the Dashpot Assembly always

- 1) Remove the Circlip from the bottom side of the dash pot
- 2) Replace the 4 parts for the DASHPOT DA PLUG M30X2
- 3) Replace the circlip to lock the DA plug in the DASHPOT

*Mounting Instructions*  
*Front End Cylinders*  
*F.L.A.S.H. series*

*Sub-Section 4A*

**mounting instructions  
front-end cylinders  
F.L.A.S.H. series**

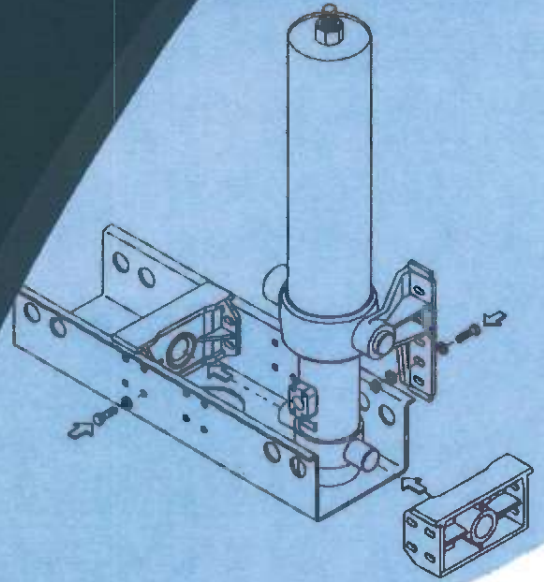

**HYVA<sup>®</sup> HYDRAULICS**

# **Mounting Instructions**

## **Front-End (FC, FE and FEE) Cylinder**

### **F.L.A.S.H. series**

### **Table of contents**

1. Introduction .....	3
1.1. Scope of use .....	3
1.2. General remarks .....	3
1.3. Safety .....	4
1.3.1. Explanation of guidance .....	4
1.3.2. Precautions .....	4
2. Guarantee .....	6
Hyva International Terms of Warranty .....	6
3. Mounting Instructions .....	8
3.1. General .....	8
3.1.1. Components .....	8
3.1.2. Mounting position and clearances .....	9
3.1.3. Cross members .....	10
3.2. Sub-frame mounting the cylinder .....	10
3.3. Cradle mounting the cylinder .....	11
3.3.1. Mounting the cradle .....	11
3.3.2. Mounting the chassis brackets into the cradle .....	12
3.4. Fixing the cylinder into the chassis brackets .....	13
3.5. Attaching the cylinder to the tipper body .....	14
3.5.1. FC cylinder .....	14
3.5.2. FE cylinder .....	14
3.6. Connecting and testing the cylinder .....	15
3.6.1. Connection of the hydraulic system .....	15
3.7. Final Checks .....	16
3.8. Painting the cylinder .....	16
4. Tables .....	18
4.1. Table 1: Bolt and nut specifications .....	18
4.2. Table 2: Recommended Cross Member Profiles and Dimensions .....	18
5. Service points .....	20

# Mounting Instructions

## Front-End (FC, FE and FEE) Cylinder

### F.L.A.S.H. series

# 1

## Introduction

*This section gives an overview of the use of this manual.*

*It also gives some basic advice on safety and precautions to be taken before and during installation.*

*Intended for experienced fitters that are new to Hyva Hydraulic equipment and also as a refresher for those already familiar with Hyva products.*

*The advice given in these pages is by no means complete and should not be used as an alternative to common sense.*

- Scope of use
- General remarks
- Safety
- Precautions

# **Mounting Instructions**

## **Front-End (FC, FE and FEE) Cylinder**

### **F.L.A.S.H. series**

## **1. Introduction**

### **1.1. Scope of use**

This manual is for work-preparation and workshops and has been written to assist with the planning and installation of the Hyva front-end cylinder and associated equipment.

The Hyva Front-end cylinder range includes cylinders with Outer Cover (FC), with Eye (FE) and with Eye/Eye (FEE).

### **1.2. General remarks**

Where a tipper is to be built-up with no sub-frame on the chassis, we strongly advise that a Hyva cradle be used to mount the cylinder. Instructions for cradle mounting of the Hyva cylinder are also given in this manual.

If the cylinder is to be fitted above the gearbox, splitter box or any part that needs periodic service, clearance must be provided between this part and the bottom of the cylinder.

It is important that the gear is fitted in the correct position, to ensure the safe and/or legal axle loading.

Specification sheets are available for all Hyva cylinders; these sheets contain all relevant dimensional and application information about your cylinder.

The Hyva cylinder has been developed for lifting purposes only and its use for any other purpose is prohibited. The cylinder is not to be used as a stabiliser and any kind of side-load must be avoided whenever possible.

#### **Warning**

***Applying side-load to any cylinder is dangerous.***

***The cylinder should be mounted with a minimum pull out of 15 mm and a maximum pull out of 50 mm (the closed length of the cylinder on the Hyva specification sheet already includes 20 mm pull out).***

If you have any questions concerning the application, installation, operation or repair of any Hyva product - please contact your nearest Hyva Service Point.

Hyva cylinders are also compatible with *biodegradable oils* such as the following synthetic ester based oils:

- BP - Biohyd SE-S
- Castrol - Carelube HES
- Texaco - Hydra
- Elf - Hydrelf Bio Safety



# **Mounting Instructions**

## **Front-End (FC, FE and FEE) Cylinder**

### **F.L.A.S.H. series**

#### **1.3. Safety**

##### **1.3.1. Explanation of guidance**

###### **Tip**

*Gives the reader advice in order to simplify certain tasks or warns of potential problems.*

###### **Warning**

*Warning of danger to the operator or product. The operator can be seriously hurt or the equipment severely damaged if the recommended procedure is not followed.*

###### **Danger**

*There is a serious threat to the life of the operator.*

##### **1.3.2. Precautions**

Ensure there is enough free working space for mounting the cylinder.

If the tipper body is on the truck chassis, lift the body using an overhead crane so that the cab protector is well clear of the cylinder.

If the tipper body is raised to create working space, support the body using body props before mounting the cylinder.

###### **Danger**

*Working under an unsupported tipper body is a danger to life.*

To avoid damage to the truck cabin, cover the rear of the cab with a tarpaulin.

If necessary tilt the vehicles cabin (see the truck manual for details).

Disconnect the vehicle's battery leads before any welding.

While lifting a cylinder the other stages can extend, to avoid this use a sling around the cover or piston and base tube (between the trunnion and anti-rattle ring). Extend the cylinder until the sling is locked and transport the cylinder using a suitable lifting device (see chapter 3.4).

###### **Warning**

*Not using the appropriate equipment when lifting parts (such as the proper sling for a cylinder) is a danger to life.*

Ensure any oil, spilt during installation and testing, is disposed of in an environmentally friendly way.

# **Mounting Instructions**

## **Front-End (FC, FE and FEE) Cylinder**

### **F.L.A.S.H. series**

2

### **Guarantee**

*This section contains an overview or guide to Hyva terms of warranty.*

*It is not complete or contractual, so in the event that you do have a problem with a Hyva product you should contact your nearest Hyva service point.*

■ Hyva International Terms of Warranty

# **Mounting Instructions**

## **Front-End (FC, FE and FEE) Cylinder**

### **F.L.A.S.H. series**

## **2. Guarantee**

### **Hyva International Terms of Warranty**

Hyva International only issues warranty to products under agreed conditions.

The following products are covered by warranty:

1. Hydraulic Cylinder
2. PTO & Pump
3. Tipping valve & Air Control
4. Oil Tank
5. Body

The warranty is only valid under the following conditions:

- 01) All Hyva products must be **installed, operated, maintained and repaired** in accordance with the relevant Hyva guidelines.
- 02) For the parts listed above, the warranty period covering is valid 12 months from date of delivery or up to a maximum, whichever comes first, of:
  - 20.000 tipping cycles for the cylinder, tipping valve, control and body.
  - 300 running hours for the PTO and pump.
  - 100.000 km for the oil tank.
- 03) The warranty period does not cover:
  - Wear of parts during normal operation (e.g. sealing set), parts made of rubber or with limited lifetime.
  - Paint coatings.
  - Damage caused by forces beyond our control.
  - Damage caused by incomplete or erroneous installation.
  - Damage caused by abusive or inappropriate operation.
  - Damage as a result of service not carried out in accordance with the Hyva Operating & Maintenance Instructions.
- 04) This warranty is valid only in accordance with the Hyva General Terms unless otherwise specified (document FO-E00000130/050721/RV AB).
- 05) A completed Claim Report shall be delivered with every claim.
- 06) All broken parts shall be kept for inspection, these parts will be returned to Hyva International for inspection on request (transportation costs to be met by end user).
- 07) Where warranty is granted, Hyva International will meet the cost of the following:
  - All necessary spare parts.
  - A replacement part where the original cannot be repaired.
- 08) Hyva International does not accept any liability for transport costs or travel expenses.
- 09) During the warranty period the equipment must be serviced at the appropriate periods (costs to be met by the end user). Checks listed in the Hyva Operating & Maintenance instructions must be completed.
- 10) Drivers must be trained to operate the Hyva equipment with the appropriate operating instructions made available.
- 11) Drivers should include the Hyva equipment in their daily vehicle inspection and arrange service for the vehicle/equipment as described in the Maintenance Instructions.

*Any variation from the conditions listed above must be agreed with Hyva prior to the operation of the equipment.*

# Mounting Instructions

## Front-End (FC, FE and FEE) Cylinder

### F.L.A.S.H. series

# 3

## Mounting Instructions

*This section makes up the main body of the mounting instructions.*

*It is separated into sections to enable you to go directly to areas you are unsure about or work through in sequence as a 'fitting course'.*

*It is separated into sections based on possible fitting arrangements i.e. with cradle or without/ FC and FE.*

*The remainder of the section covers mounting of the cylinder on to the vehicle or trailer, attaching to the body and connection & testing.*

- General
- Components
- Mounting position and clearances
- Cross members
- Sub-frame mounting the cylinder
- Cradle mounting the cylinder
- Mounting the cradle
- Mounting the chassis brackets into the cradle
- Fixing the cylinder into the chassis brackets
- Attaching the cylinder to the tipper body
- FC cylinder
- FE cylinder
- Connecting and testing the cylinder
- Connection of the hydraulic system
- Final Checks
- Painting the cylinder

# Mounting Instructions

## Front-End (FC, FE and FEE) Cylinder F.L.A.S.H. series

### 3. Mounting Instructions

#### 3.1. General

##### 3.1.1. Components

The basic components of the Hyva front end cylinders are as shown in Figure 1:

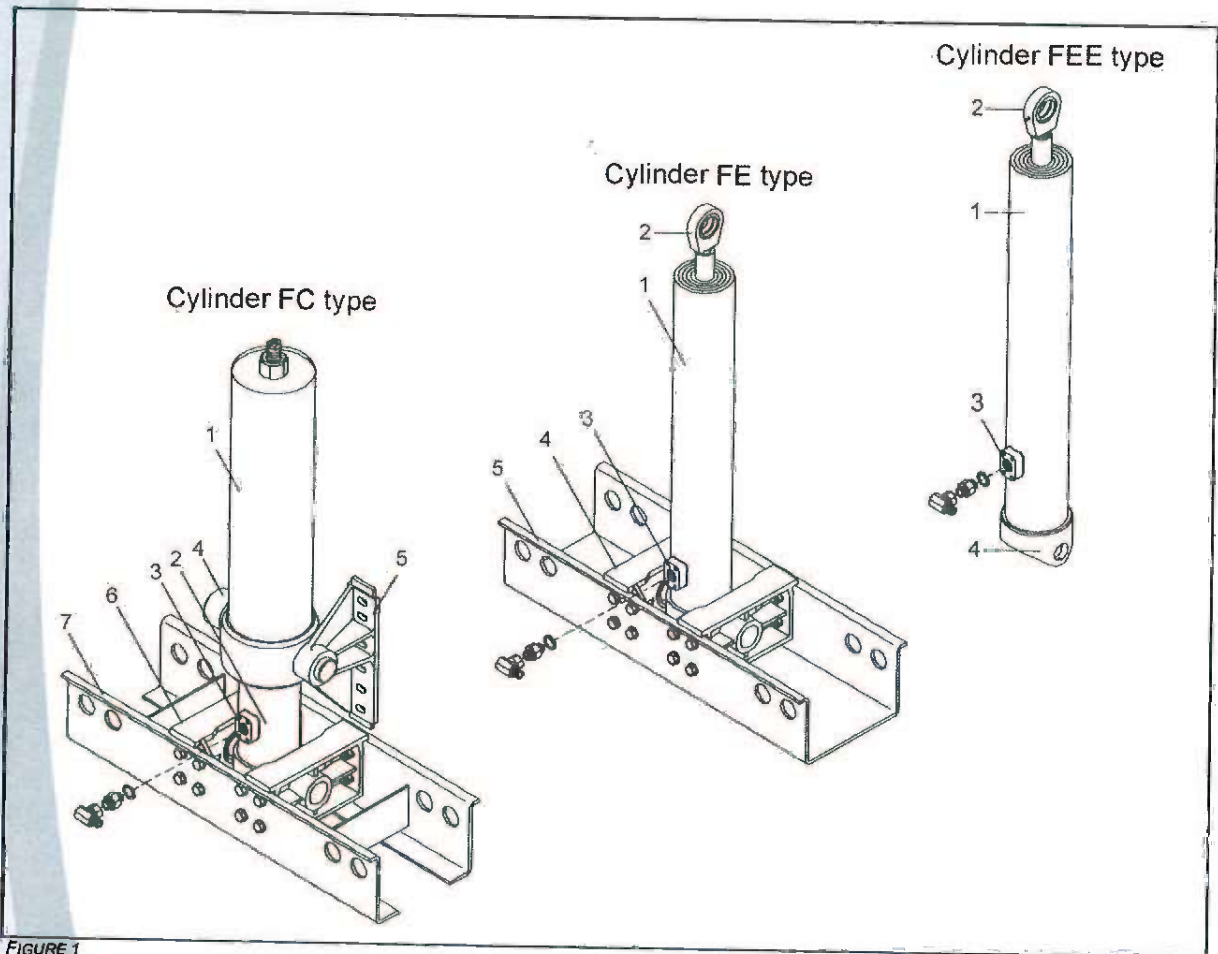

FIGURE 1

#### FC type (Front-end Cover)

1. Cylinder (Cover)
2. Cylinder (Main Body)
3. SAE Oil Inlet
4. Right Hand Body Bracket
5. Left Hand Body Bracket
6. Chassis Bracket
7. Bracket Cradle

#### FE type (Front-end Eye)

1. Cylinder
2. Piston Eye
3. SAE Oil Inlet
4. Chassis Brackets
5. Bracket Cradle

#### FEE type (Front-end Eye-Eye)

1. Cylinder
2. Piston Eye
3. SAE Oil Inlet
4. Base Eye

# **Mounting Instructions**

## **Front-End (FC, FE and FEE) Cylinder**

### **F.L.A.S.H. series**

#### **3.1.2. Mounting position and clearances**

The mounting position of the cylinder will depend on the application requirements of the cylinder and the safe/legal axle loading of the vehicle.

The application requirements (lifting capacity and tipping angle) of the cylinder are governed by the load capacity of the vehicle and the physical shape of the body (overhang, body-length, pivot point, etc.). The axle loading for the vehicle is governed by legal requirements in the country of use and the specification of the vehicle manufacturer.

#### **Tip**

*For minimum body weight use:*

*body volume (L\*w\*h – in metres) \* specific mass of sand (1.6 ton/m<sup>3</sup>)*

If you are unsure of any of these details – please contact your nearest Hyva Service Point, who will advise on suitable fitting position for your application.

Additional factors that may affect the mounting position:

1. Cab clearance – ensure enough clearance is left between the body and cab, allow for tilting of the cab, movement of the body during tipping and access to other equipment in the mounting area
2. Rotation clearance – during tipping the cylinder rotates about its lower bracket, ensure there is enough clearance around the lower part of the cylinder body, cab and gearbox
3. End of stroke clearance – check there is at least 50mm clearance between the front of the body and the stages of the cylinder at the end of its stroke
4. Maintenance access – remember to allow space for the use of tools, connection of hoses and so on during fitting and service

#### **Caution**

*The maximum build-in angle for FC cylinders depends on cover length.*

*As a rule of thumb:*

*Cylinders with long cover (small closed length) can be build in up to 10°*

*Cylinders with short cover (big closed length) can be build in up to 20°*

*(angle from the vertical)*

*For more detailed information see cylinder specification sheet.*

*The maximum build-in angle for FE/FEE cylinders is 30° from the vertical plane.*

*The cylinder should be mounted with a minimum pull out of 15 mm and a maximum pull out of 50 mm (the closed length of the cylinder on the Hyva specification sheet already includes 20 mm pull out).*

*Where a 'knock-off' or other end of stroke device is to be used remember to allow 150mm of stroke for front-end cylinders to activate the device.*

# Mounting Instructions

## Front-End (FC, FE and FEE) Cylinder

### F.L.A.S.H. series

#### 3.1.3. Cross members

See the cylinder specification sheet for the minimum distance between the support cross members. Allow free distance for rotation of the cylinder during tipping (rotation is approximately half the tipping angle).

Cross members for the chassis brackets (see Figure 2), must be of sufficient cross section to withstand the cylinder load. See manufacturer's guide and table 2 for recommended cross member profiles and dimensions.

Allow maximum 2mm clearance between the cylinder and chassis brackets for assembly and removal.

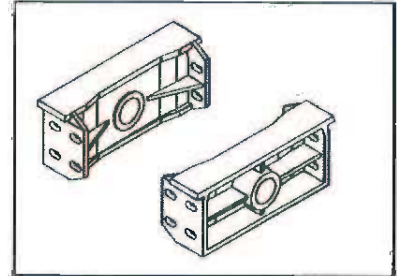

FIGURE 2

#### 3.2. Sub-frame mounting the cylinder

Position one of the chassis brackets, hand-tighten the required bolts, self-locking nuts and washers, (see bracket specification sheet). See Figure 3 for position and orientation of chassis brackets.

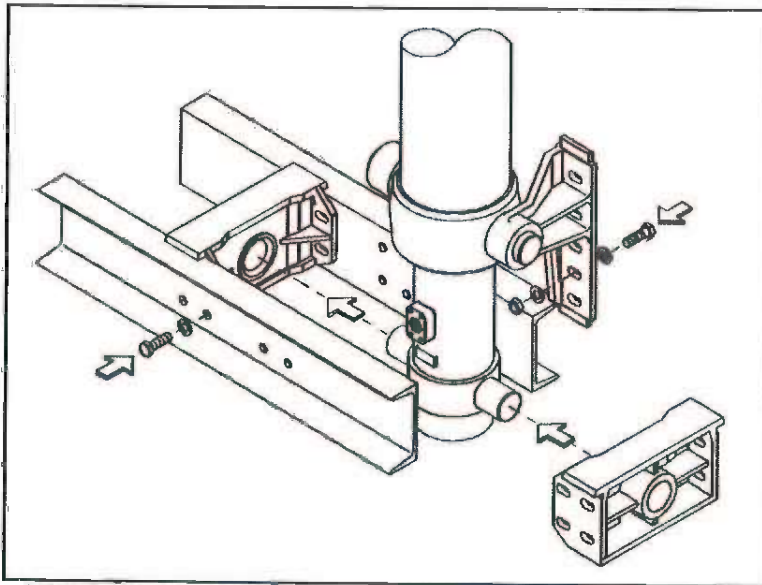

FIGURE 3: MOUNTING THE CYLINDER INTO THE SUB FRAME

Ensure there is enough clearance between the top of the cross member and the bottom of the cylinder at full extension. See specification sheet for details.

For sequence see section 3.4.

# Mounting Instructions

## Front-End (FC, FE and FEE) Cylinder F.L.A.S.H. series

### 3.3. Cradle mounting the cylinder

#### 3.3.1. Mounting the cradle

Set the height of the cradle (see Figure 4) to allow clearance for the gearbox etc., using standard rectangular or U-profile channels.

Use manufacturer's recommended subframe profiles for channel dimensions

Channel must be angled with rounded edges to minimise stress on the chassis

Fabricate the attachment plates to run down to the chassis from the underside of the cradle.

The brackets must run the full width of the cradle and about 2/3 of the depth of the chassis (minimum 100mm).

Where the attachment plate coincides with parts on the chassis (such as a suspension bracket), the plate may be cut to fit. Follow the shape of the bracket as closely as possible using rounded corners. Refer to the truck manufacturer's guide before moving any vehicle components. It may be possible to reposition the parts on the chassis or fit the plate behind.

If the chassis is formed at the fixing points, the attachment plates may be formed to suit. If necessary the plates can be cut and welded at the required angle with the stiffener rib over the weld.

Bolt the attachment plates to the chassis (see Figure 5). Use a minimum of four M16x1.25 quality 8.8 bolts per plate and existing holes wherever possible.

Weld the cradle to the attachment plates (see Figure 6)

Fully weld the cradle, attachment plates and cradle.

Ensure the attachment plate is welded the full width of the underside of the cradle.

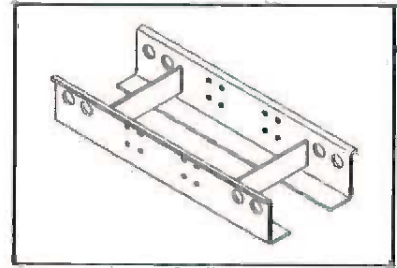

FIGURE 4

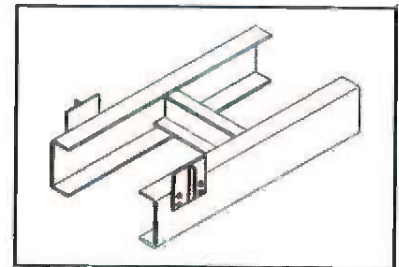

FIGURE 5

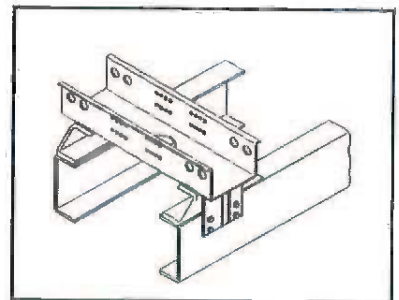

FIGURE 6

#### **Warning**

**Disconnect the battery leads before welding.**

If the cradle is to be removable, we recommend the cradle be fixed as shown in Figure 7.



## **Mounting Instructions** **Front-End (FC, FE and FEE) Cylinder** **F.L.A.S.H. series**

### **3.3.2. Mounting the chassis brackets into the cradle**

Position one of the chassis brackets, hand-tighten the required bolts, self-locking nuts and washers, See Figure 8 for position and orientation of chassis brackets.

Use the pre-drilled holes in the cradle when mounting the chassis brackets. Use the bracket specification sheet to determine the correct holes.

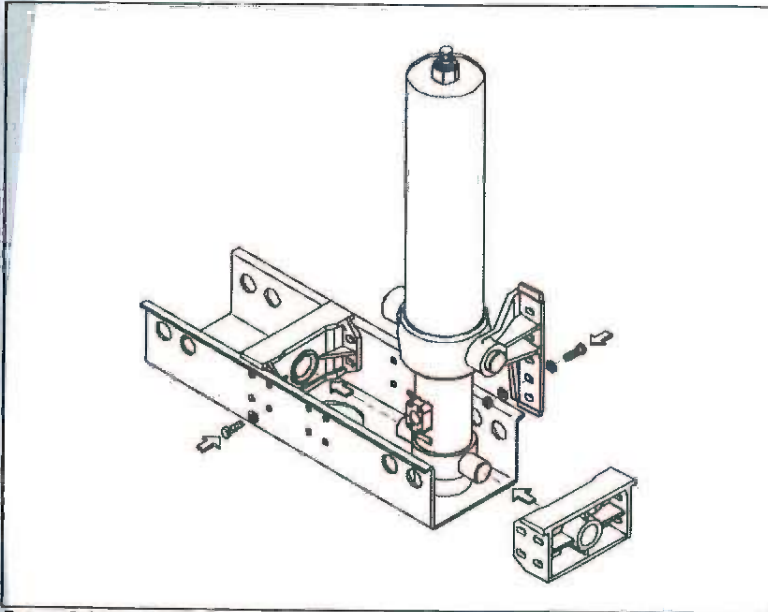

FIGURE 8: MOUNTING THE CYLINDER INTO THE CRADLE

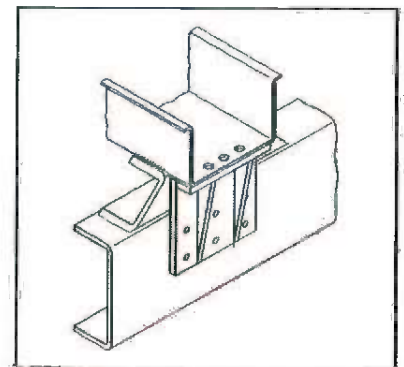

FIGURE 7

For sequence see section 3.4

**Note:**

All brackets are equipped with maintenance free bearings.

## **Mounting Instructions**

### **Front-End (FC, FE and FEE) Cylinder**

#### **F.L.A.S.H. series**

#### **3.4. Fixing the cylinder into the chassis brackets**

##### **Warning**

*Not using proper slings is danger to life.*

Be careful that while lifting the cylinder the stages may extend. For easy lifting of FC cylinders, a lifting eye bolt is available, which can be mounted in top of piston head, see Figure 10 (Part no. 71875105).

Wrap the sling around the outer cover and base (for FE types use the base), and transport it using an overhead crane, or other suitable lifting device.

Before mounting the cylinder, remove the protective caps.

Position one of the cylinder pins into the pre-placed chassis bracket (see Figure 3 or Figure 8). Make sure the oil inlet is facing the right direction for connection of the hydraulic system.

Fix the second chassis bracket and align the cylinder with the centre of the truck chassis (see Figure 3 or Figure 8.). Be aware of the 2 mm maximum clearance between cylinder and brackets. Tighten all bolts securely (see Table 1 for required torque).

##### **Warning**

*After removing the sling, the cylinder may fall towards the cab, this can result in injuries to persons or damage of components.*

To hold the cylinder in the correct position, place wooden wedges or blocks between the cylinder and the chassis (see Figure 10). Remove the sling. As mentioned above, the lifting eye bolt can be mounted in the piston head.

##### **Tip**

*If only the tipping gear is to be fitted (i.e. the body is to be fit elsewhere) secure the cylinder and brackets to prevent damage during transport. Lean the cylinder (and rear brackets) back and secure to chassis with ropes.*

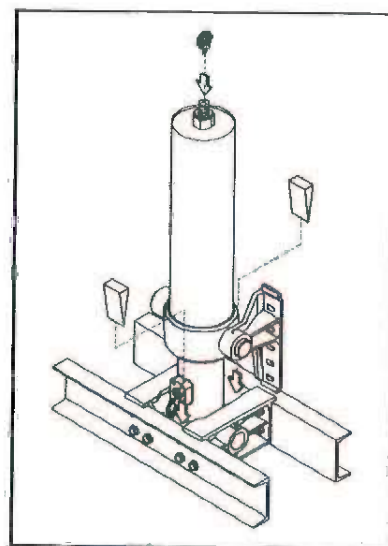

FIGURE 10

# Mounting Instructions

## Front-End (FC, FE and FEE) Cylinder

### F.L.A.S.H. series

### 3.5. Attaching the cylinder to the tipper body

#### 3.5.1. FC cylinder

Remove the protective caps from the cover and lightly grease the pins with SAE 140 grease or equivalent. Place the lifting brackets (Figure 11) on the cover pins and attach them to the tipping body. See Figure 12. The brackets are equipped with maintenance free bearings.

Ensure the lifting brackets are in the correct position and orientation with a maximum of 2mm clearance between the cover and brackets. The nuts and washers should be on the bracket flanges, if there is not enough space they may be reversed.

Tighten all bolts securely (see Table 1 for required torque).

*Tip*

*The lifting bracket holes may not be in-line with the tipping body holes. The cylinder can be carefully extended hydraulically or by physically pulling out the small inner (piston), the tipping body can also be lowered.*

For sequence see section 3.6.

If the cover is likely to make contact with the body and rattle use rubber block (092.12.016) to reduce noise and damage, but only if cylinder is vertical mounted (angle 0°).

#### 3.5.2. FE cylinder

Attach the piston eye to the tipping body (see Figure 13). Actual attachment method will depend on eye and top bracket type (see bracket specification sheet for details). In general fit the pivot pin and secure with split pin.

Ensure the bearing has sufficient free working space ( $2 \times 6^\circ$ ) and where necessary use filler rings to close the gap between bearing and bracket.

For sequence see section 3.6.

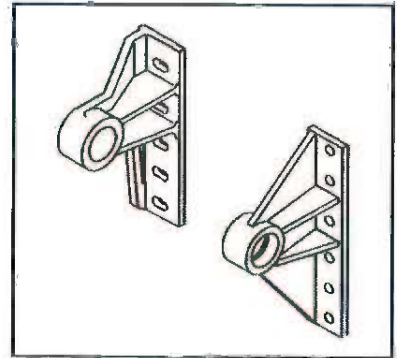

FIGURE 11

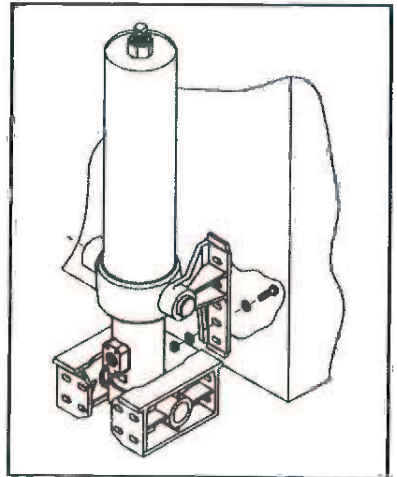

FIGURE 12

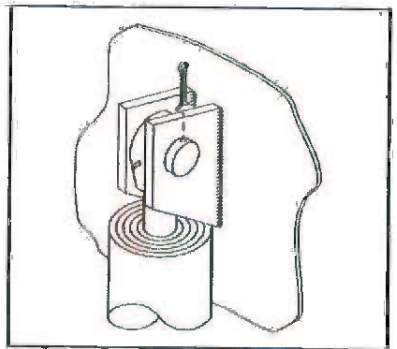

FIGURE 13

## **Mounting Instructions**

### **Front-End (FC, FE and FEE) Cylinder**

#### **F.L.A.S.H. series**

### **3.6. Connecting and testing the cylinder**

#### **3.6.1. Connection of the hydraulic system**

Connect the hydraulic system as specified by the hydraulic kit. Remove the plug from the oil-inlet and connect the cylinder to the hydraulic system (Figure 14). Ensure there is sufficient hose so does not obstruct the movement of the cylinder while tipping.

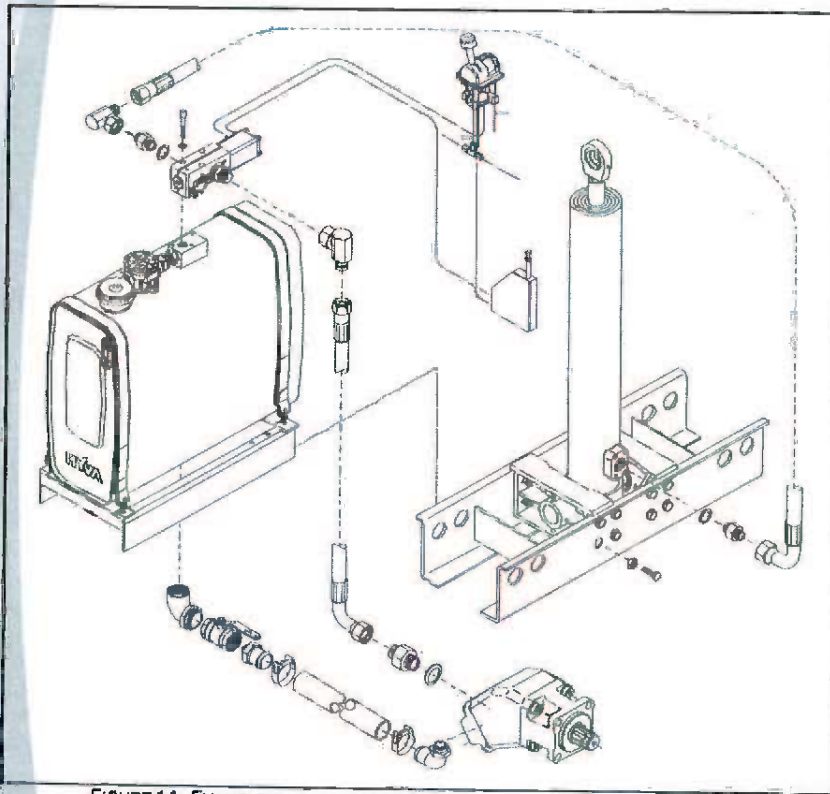

FIGURE 14: EXAMPLE OF A HYDRAULIC SYSTEM

#### **Tip**

Test oil may leak from the cylinder when the plug is removed.

# **Mounting Instructions**

## **Front-End (FC, FE and FEE) Cylinder**

### **F.L.A.S.H. series**

#### **3.7. Final Checks**

The first tip should be slow and all movements are to be closely observed to check:

- cylinder movement is smooth.
- hoses do not interfere with any parts.
- cylinder extends in a straight line.
- while tipping, there is no contact between the rear end of the body and other parts of the truck (such as towing-hooks, tail lamps etc.).

Tip the body 4 or 5 times and check there is no side-load on the cylinder and the clearances are correct. If you find the cylinder movement is stiff, loosen the bolts and realign the cylinder. Protect hoses where they move against metal parts (if they can not be repositioned). It is not necessary to bleed air from the cylinder.

*Tip*

---

*During the first few tips some packset grease may appear on the stages of the cylinder, this is normal and does not mean the cylinder is leaking.*

Where the installation does not operate as expected, see "Operating & Maintenance Instructions – Complete Tipper" for full details of use including trouble-shooting guide (Hyva document: TIP-0005).

#### **3.8. Painting the cylinder**

Hyva cylinders are painted with 40 microns of black primer (RAL 9005). When painting the body, do not repaint the blank parts of cylinder e.g. trunnion pins, piston, stages, wipers, balls/eyes.

For small FE cylinders it is possible that the first outgoing stage sticks out instead of the piston. In this case use preservation grease on the tube that is sticking out. The grease must be oil based (not wax based). Use Hyva packset grease, Shell Ensyls or equivalent.

It is also advised to keep as close as possible to the build-in dimension on cylinder specification sheet to have a pull-out of 20 mm.

# **Mounting Instructions**

## **Front-End (FC, FE and FEE) Cylinder**

### **F.L.A.S.H. series**

# 4

### **Tables**

*Specifications and helpful advice for use during fitting.*

- Table 1: Bolt and nut specifications
- Table 2: Recommended Cross Member Profiles and Dimensions

# Mounting Instructions

## Front-End (FC, FE and FEE) Cylinder

### F.L.A.S.H. series

#### 4. Tables

##### 4.1. Table 1: Bolt and nut specifications

Size	DIN		Quality	Torque
	Bolt	Nut		
M12	931	985	8.8	80 Nm
M16	931	985	8.8	210 Nm

TABLE 1: BOLT AND NUT SPECIFICATIONS

##### 4.2. Table 2: Recommended Cross Member Profiles and Dimensions

Tipping Weight (ton)	Minimum $W_{xx}$ ( $cm^3$ )	Hot Rolled UNP (yield 235 MPa)	Cold Rolled U (yield 235 MPa)	Box Profile (yield 235 MPa)
Upto 7.5	30	-	100x50x6	100x50x5
Upto 10	40	100	120x60x6	100x60x6
Upto 15	60	120	140x65x6	120x60x6
Upto 20	80	140	-	140x60x8
Upto 25	100	160	-	140x70x8
Upto 35	140	180	-	160x80x8
35 and over	140+	200	-	180x80x8

Note: All strength calculations based on St.37-2 and cross-member length of 1m.

TABLE 2: RECOMMENDED CROSS MEMBER PROFILES AND DIMENSIONS

# **Mounting Instructions**

## **Front-End (FC, FE and FEE) Cylinder**

### **F.L.A.S.H. series**

5

#### **Service points**

*An overview of main (or national) service agents to contact in the event your Hyva equipment does not perform as you expect.*

*Even if you are considerable distance from the agents listed, you should still contact your nearest agent. Most agents maintain their own networks and can advise you of the most convenient for your work.*



# Mounting Instructions

## Front-End (FC, FE and FEE) Cylinder

### F.L.A.S.H. series

## 5. Service points

**Hyva International B.V.**  
Ondernemingsweg 1  
2404 HM Alphen aan den Rijn  
The Netherlands  
Telephone (31) 172 - 42 35 55  
Telefax (31) 172 - 43 31 96  
[info@hyva.com](mailto:info@hyva.com)

**Hyva Nederland B.V.**  
Ondernemingsweg 1  
2404 HM Alphen aan den Rijn  
Nederland  
Telefoon (31) 172 - 42 35 55  
Telefax (31) 172 - 41 38 97  
[nederland@hyva.com](mailto:nederland@hyva.com)

**Hyva France S.A.**  
Rue de la Grande Prée  
Z.I. du Meux - B.P. 50317  
60618 La Croix Saint Ouen Cedex  
France  
Téléphone (33) (0) 3 44 41 50 00  
Télécopieur (33) (0) 3 44 41 72 00  
[info@hyva.fr](mailto:info@hyva.fr)

**Hyva Belgium N.V. - S.A.**  
Industriepark / Z.I. Blauwe Steen  
Blauwe Steenstraat 85  
2550 Kontich  
Belgium  
Telefoon (32) 3 - 450 70 20  
Telefax (32) 3 - 458 13 85  
[info@hyva.be](mailto:info@hyva.be)

**Hyva GmbH**  
Marie-Bernays-Ring 25A  
41199 Mönchengladbach-Güdderath  
Industriegebiet West  
Deutschland  
Telefon (49) 2166 - 959 70  
Telefax (49) 2166 - 959 749  
[info@hyva.de](mailto:info@hyva.de)

**Hyva (U.K.) Limited.**  
10 Huntsman Drive  
Northbank Industrial Estate, Irlam  
Manchester M44 5EG  
United Kingdom  
Telephone (44) 161 - 77 66 600  
Telefax (44) 161 - 77 66 619  
[info@hyva.co.uk](mailto:info@hyva.co.uk)

**Hyva Ibérica S.A.**  
Poligono Clot de Moja  
C/Ult de Liebre No. 7  
08734 Olérdola, (Moja, Barcelona)  
España  
Teléfono (34) 93 - 89 02 044  
Fax (34) 93 - 89 02 867  
[info@hyvaiberica.es](mailto:info@hyvaiberica.es)

**Hyva Polska Sp.z o.o.**  
Ul. Mysliwska 68  
30 - 718 Krakow  
Poland  
Telephone (48) 12 658 65 05  
Telefax (48) 12 658 44 39  
[office@hyva.com.pl](mailto:office@hyva.com.pl)

**Hyva Transporttechnik GmbH**  
Bahnhofstrasse 60  
4810 Gmunden  
Österreich  
Telefon (43) 7612 630 03  
Telefax (43) 7612 630 03 - 33  
[hyva@aon.at](mailto:hyva@aon.at)

**Hyva do Brasil Hidráulica Ltda.**  
Rua Evaristo De Antoni 780  
95041 - 000 Sao José  
Caxias do Sul - RS  
Brazil  
Telephone (55) 54 - 224 34 33  
Telefax (55) 54 - 224 34 33  
[hyva@maibanet.com](mailto:hyva@maibanet.com)

**Hyva (Malaysia) SDN. BHD.**  
Lot no.3, Jalan 3/37A  
Taman Bukit Maluri Industrial Area-  
Kepong 52100, Kuala Lumpur  
West Malaysia  
Telephone (60) 3 - 62 74 73 19  
Telefax (60) 3 - 62 74 74 75  
[hyva@the.net.my](mailto:hyva@the.net.my)

**Hyva Thailand Co. Ltd.**  
18/8 Bangna-trad Rd M007  
Tambol Babgchalang Amphuur  
Bangplee, Samutprakarn  
Thailand  
Telephone (66) 2 - 75 08 547  
Telefax (66) 2 - 75 08 548  
[hyvath@lox1.loxinfo.co.th](mailto:hyvath@lox1.loxinfo.co.th)

**Hyva India Transportation Sys. Pvt. Ltd.**  
C112, MIDC,  
Pawane,  
Navi Mumbai - 400-705,  
India  
Telephone (91) 22 - 5616 54 40/45  
Telefax (91) 22 - 2787 28 46  
[hyvaingd@bom3.vsnl.net.in](mailto:hyvaingd@bom3.vsnl.net.in)

**Hyva Maroc S.A.R.L.**  
386 Boulevard Chefchouni  
Quartier Industriel Ain Sebba  
20250 Casablanca  
Maroc  
Telephone +212 (0) 22 66 26 46  
Telefax +212 (0) 22 66 26 46  
[hyvamaroc@menara.ma](mailto:hyvamaroc@menara.ma)

**Hyva Mechanics Co. Ltd.**  
18 Sha Wan Road  
Guangling Industrial Park  
Yangzhou  
People's Republic of China  
Telephone +86 (0) 514 78 29 969  
Telefax +86 (0) 514 78 17 938  
[sales@hyva.com.cn](mailto:sales@hyva.com.cn)

**Hyva Rusland**  
4th floor, Laboratory bldg.  
VNIMETMASH  
8a, Ryazanskiy prospect  
109428 Moscow  
Telephone +7 4 95 739 35 18  
[office@hyva.ru](mailto:office@hyva.ru)

**Hyva Baltic SIA**  
Peries 1, Sigulda  
Rigas Rajons LV 2150  
Latvia  
Telephone +317 770 34 81  
Telefax +317 770 34 81  
[janis.hyvabaltic@biv.lv](mailto:janis.hyvabaltic@biv.lv)

**Hyva-CS s.r.o.**  
Sudomerska 9  
CZ - 130 00 Praha 3  
Czech Republic  
Telephone +420 222 711 427  
Telefax +420 222 711 427  
[hyva.sk@hyva.cz](mailto:hyva.sk@hyva.cz)

**Hyva Corporation (U.S.A.)**  
1395 East Irving Park Road  
Itasca, Illinois 60143  
United States of America  
Telephone +1 630 773 9020  
Telefax +1 630 773 9029  
[hyva\\_usa@sbcglobal.net](mailto:hyva_usa@sbcglobal.net)

**Kennis' Machinefabriek B.V.**  
Geuzendijk 74  
6021 PV Budel  
The Netherlands  
Telephone (31) 495 - 43 18 88  
Telefax (31) 495 - 43 02 90  
[sales@kennis.com](mailto:sales@kennis.com)

**Technamics B.V.**  
Zeppelinstraat 21  
7903 BR Hoogeveen  
The Netherlands  
Telephone (31) 528 - 22 98 50  
Telefax (31) 528 - 26 62 11  
[info@technamics.nl](mailto:info@technamics.nl)

**Hydraulic Floor Systems B.V.**  
Ondernemingsweg 1  
2404 HM Alphen aan den Rijn  
The Netherlands  
Telephone (31) 172 - 42 35 55  
Telefax (31) 172 - 43 31 96  
[hyvafloor@hyva.com](mailto:hyvafloor@hyva.com)

*Repair Instructions*  
*Front End Cylinders*  
*F.L.A.S.H. series*

*Sub-Section 4B*

**Repair instructions  
front-end cylinders  
F.L.A.S.H. series**



**HYVA<sup>®</sup> HYDRAULICS**

# Repair Instructions

## Front-End FC, FE and FEE type F.L.A.S.H.

### Table of contents

1. Introduction .....	3
1.1. Scope of use .....	3
1.2. General remarks .....	3
1.3. Safety .....	4
1.3.1. Explanation of guidance .....	4
1.3.2. Precautions .....	4
1.4. Spare parts .....	4
1.4.1. General .....	4
1.4.2. Storage .....	5
1.4.3. Prior to use .....	5
1.5. Recycling .....	5
1.5.1. General .....	5
1.5.2. Reuse of components .....	5
2. Guarantee .....	8
Hyva International Terms of Warranty .....	8
3. Repair Instructions .....	10
3.1. General .....	10
3.1.1. Components .....	10
3.1.2. Removing the cylinder from the vehicle .....	11
3.1.3. Refitting the cylinder to the vehicle .....	14
3.2. Dismantling the cylinder .....	14
3.2.1. Removing piston eye/head .....	15
3.2.2. Opening the base .....	15
3.2.3. Removing the piston .....	16
3.2.4. Removing the stages .....	16
4. Assembly .....	19
4.1. Replacing packset .....	19
4.2. Replacing Stages .....	20
4.3. Fitting piston eye/head .....	21
4.4. Closing the cylinder (all types) .....	21
5. Connecting and testing the cylinder .....	24
5.1. Connection of the hydraulic system .....	24
5.2. Final Checks .....	24
5.3. Painting the cylinder .....	24
6. Tables .....	26
6.1. General .....	26
6.2. FC cylinders – Parts and tools .....	27
7. Service points .....	29

# Repair Instructions

## Front-End FC, FE and FEE type F.L.A.S.H.

# 1

### Introduction

*This section gives an overview of the use of this manual.*

*It also gives some basic advice on safety and precautions to be taken before and during installation.*

*Intended for experienced fitters that are new to Hyva Hydraulic equipment and also as a refresher for those already familiar with Hyva products.*

*The advice given in these pages is by no means complete and should not be used as an alternative to common sense.*

- Scope of use
- General remarks
- Explanation of guidance
- Precautions
- Spare parts
- Recycling
- Reuse of components

# Repair Instructions

## Front-End FC, FE and FEE type F.L.A.S.H.

### 1. Introduction

#### 1.1. Scope of use

This manual is for repair workshops and service agents repairing the Hyva front-end cylinders, where it is necessary to disassemble the cylinder to replace parts that are subject to wear (i.e. seal kit).

The Hyva cylinder range includes Front-end Outer Cover (FC), Eye (FE), Eye-Eye (FEE) and Gimbal (FEG) type cylinders. Separate instructions are available for other types of cylinder.

The guarantee is invalidated if:

- Components other than original Hyva parts are used.
- Hyva components are altered in any way.
- Repairs to the cylinder are not in accordance with Hyva instructions.

#### 1.2. General remarks

Where a tipper is to be built-up with no sub-frame on the chassis, we strongly advise that a Hyva cradle be used to mount the cylinder. Instructions for cradle mounting of the Hyva cylinder are also given in this manual.

If the cylinder is to be fitted above the gearbox, splitter box or any part that needs periodic service, clearance must be provided between this part and the bottom of the cylinder.

It is important that the gear is fitted in the correct position, to ensure the safe and/or legal axle loading.

Specification sheets are available for all Hyva cylinders; these sheets contain all relevant dimensional and application information about your cylinder. Specification sheets are available from your nearest Hyva service point.

The Hyva cylinder has been developed for lifting purposes only and its use for any other purpose is prohibited. The cylinder is not to be used as a stabiliser and any kind of side-load must be avoided whenever possible. Dynamic effects, like shunting, should be avoided to prevent pressure peaks and serious cylinder/vehicle failure caused by overpressure and/or buckling.

#### **Warning**

***Applying side-load and dynamic forces to any cylinder is dangerous.***

***The cylinder should be mounted with a minimum pull out of 15 mm and a maximum pull out of 50 mm (the closed length of the cylinder on the Hyva specification sheet already includes 20 mm pull out).***

If you have any questions concerning the application, installation, operation or repair of any Hyva product - please contact your nearest Hyva Service Point.

Hyva cylinders are also compatible with *biodegradable oils* such as the following synthetic ester based oils:

- BP - Biohyd SE-S
- Castrol - Carelube HES
- Texaco - Hydra
- Elf - Hydrelf Bio Safety

Biodegradable oils attract water, for this reason it is important to use a Hyva *air filter with dehumidifier* (part number: 14810590).

# Repair Instructions

## Front-End FC, FE and FEE type F.L.A.S.H.

### 1.3. Safety

#### 1.3.1) Explanation of guidance

##### Tip

*Gives the reader advice in order to simplify certain tasks or warns of potential problems.*

##### Warning

*Warning of danger to the operator or product. The operator can be seriously hurt or the equipment severely damaged if the recommended procedure is not followed.*

##### Danger

*There is a serious threat to the life of the operator.*

#### 1.3.2. Precautions

Ensure there is enough free working space for mounting the cylinder. If the tipper body is on the truck chassis, lift the body using an overhead crane so that the cab protector is well clear of the cylinder. If the tipper body is raised to create working space, support the body using body props before mounting the cylinder.

##### Danger

*Working under an unsupported tipper body is a danger to life.*

To avoid damage to the truck cabin, cover the rear of the cab with a tarpaulin. If necessary tilt the vehicles cabin (see the truck manual for details). Disconnect the vehicle's battery leads before any welding.

While lifting a cylinder the other stages can extend, to avoid this use a sling around the cover or piston and base tube (between the trunnion and anti-rattle ring). Extend the cylinder until the sling is locked and transport the cylinder using a suitable lifting device.

##### Warning

*Not using the appropriate equipment when lifting parts (such as the proper sling for a cylinder) is a danger to life.*

*Some parts in the cylinder are mounted under tension (i.e. snap rings) they may spring out when removed. They should be secured when removed to prevent injury.*

Ensure any oil spilt during installation and testing is disposed of in an environmentally friendly way.

### 1.4. Spare parts

#### 1.4.1. General

We have continuous development programmes to improve our products, which means parts may have been changed between fitting and repair. To avoid ordering the wrong parts we recommend ordering spare parts listed on the relevant specification sheet.

# **Repair Instructions**

## **Front-End FC, FE and FEE type F.L.A.S.H.**

### **1.4.2. Storage**

Unless otherwise stated, Hyva spare parts are delivered suitable for storage as described in this section. Provided the following basic conditions are met:

- Internal – protected from extreme temperatures, rain and corrosive atmospheres.
- Clean – free from excessive dust and dirt
- Dry – minimal humidity and sheltered from water vapour and steam

*Spare parts must not be stored externally under any conditions.*

1. **Cylinders** (including Tubes, Bases and Covers)  
Supplied suitable for 18 months storage under the above conditions. These parts should be stored flat on pallets, no more than 6 (tubes) high to avoid deformation. Damage to the inside- & outside-diameters and grooves will make parts unusable and must be avoided
2. **Non-metallic parts** (Seals, Wipers and Wear-rings)  
Should be kept in packaging (bags or boxes) until required for use. Items suitable for storage for up to 2 years.
3. **Metallic parts** (Sliders, Snap-rings, Spacers, PTO's and Pumps)  
Supplied with light duty protective layer. Should be kept in packaging (bags or boxes) until required for use. Items suitable for storage for up to 2 years

### **1.4.3. Prior to use**

Clean all parts to remove any dust, dirt or protective coatings. Check parts for damage during transport or storage. Do not use any damaged parts

*If for any reason the above conditions can not be met contact your nearest Hyva Service Point for further guidance.*

## **1.5. Recycling**

### **1.5.1. General**

Remove and dismantle the components as described in this manual. Clean all parts thoroughly (using degreaser and compressed air). All oil products must be disposed of in an environmentally friendly manner (usually by a licensed disposal agent). The components can then be recycled in the normal way. For example; non metal components such as seals and wipers with plastic materials, clean steel parts with other scrap metals.

### **1.5.2. Reuse of components**

When the Hyva cylinder is stripped (for example after decommissioning a cylinder) some parts may be reused.

#### **Warning**

*Never use parts from a cylinder that has been subject to over-pressure, mismatching or side-load.*

*Using second hand parts in cylinder repairs can change the function or operating conditions of the cylinder and may affect the terms of warranty.*



## **Repair Instructions**

### **Front-End FC, FE and FEE type F.L.A.S.H.**

Assuming the following parts are in good working order (i.e. no visible damage such as scratches, imprints or deformation, no corrosion and dimensionally correct) then they may be reused:

- Bases, Stages, Pistons and Covers,
- Sliders, Locking Plates, Bottom Plate
- Eyes, Eye Bushes, Eye Bearings, Lift rings when not deformed during dismantling
- Cradle, Chassis Brackets and Body Brackets

The following parts must *never* be reused:

- Packset (seals, wear-rings, wipers)
- O-rings
- Top-nut & washer
- Inner stop-rings
- Locking pin for threaded piston eye/head

# **Repair Instructions**

## **Front-End FC, FE and FEE type F.L.A.S.H.**

2

### **Guarantee**

*This section contains an overview or guide to Hyva terms of warranty.*

*It is not complete or contractual, so in the event that you do have a problem with a Hyva product you should contact your nearest Hyva service point.*

- Hyva International Terms of Warranty

# **Repair Instructions**

## **Front-End FC, FE and FEE type F.L.A.S.H.**

### **2. Guarantee**

#### **Hyva International Terms of Warranty**

Hyva International only issues warranty to products under agreed conditions.

The following products are covered by warranty:

1. Hydraulic Cylinder
2. PTO & Pump
3. Tipping valve & Air Control
4. Oil Tank
5. Body

The warranty is only valid under the following conditions:

- 01) All Hyva products must be **installed, operated, maintained and repaired** in accordance with the relevant Hyva guidelines.
- 02) For the parts listed above, the warranty period covering is valid 12 months from date of delivery or up to a maximum, whichever comes first, of:
  - 20.000 tipping cycles for the cylinder, tipping valve, control and body.
  - 300 running hours for the PTO and pump.
  - 100.000 km for the oil tank.
- 03) The warranty period does not cover:
  - Wear of parts during normal operation (e.g. sealing set), parts made of rubber or with limited lifetime.
  - Paint coatings.
  - Damage caused by forces beyond our control.
  - Damage caused by incomplete or erroneous installation.
  - Damage caused by abusive or inappropriate operation.
  - Damage as a result of service not carried out in accordance with the Hyva Operating & Maintenance Instructions.
- 04) This warranty is valid only in accordance with the Hyva General Terms unless otherwise specified (document FO-E00000130/21-07-05/Rv AB).
- 05) A completed Claim Report shall be delivered with every claim.
- 06) All broken parts shall be kept for inspection, these parts will be returned to Hyva International for inspection on request (transportation costs to be met by end user).
- 07) Where warranty is granted, Hyva International will meet the cost of the following:
  - All necessary spare parts.
  - A replacement part where the original cannot be repaired.
- 08) Hyva International does not accept any liability for transport costs or travel expenses.
- 09) During the warranty period the equipment must be serviced at the appropriate periods (costs to be met by the end user). Checks listed in the Hyva Operating & Maintenance instructions must be completed.
- 10) Drivers must be trained to operate the Hyva equipment with the appropriate operating instructions made available.
- 11) Drivers should include the Hyva equipment in their daily vehicle inspection and arrange service for the vehicle/equipment as described in the Maintenance Instructions.

*Any variation from the conditions listed above must be agreed with Hyva prior to the operation of the equipment.*

## **Repair Instructions**

### **Front-End FC, FE and FEE type F.L.A.S.H.**

# 3

### **Repair Instructions**

*This section makes up the main body of the repair instructions.*

*It is separated into sections to enable you to go directly to areas you are unsure about or work through in sequence as a 'repair course'.*

*The first part gives information about the nature and appearance of each type of cylinder. How to prepare the cylinder for disassembly by disconnecting from the body and then removal from the chassis.*

*The remainder of the section covers opening of the base, removal of piston and then stages.*

- General
- Components
- Removing the cylinder from the vehicle
- Refitting the cylinder to the vehicle
- Dismantling the cylinder
- Removing piston eye/head
- Removing the stages

# Repair Instructions

## Front-End FC, FE and FEE type F.L.A.S.H.

### 3. Repair Instructions

#### 3.1. General

##### 3.1.1. Components

Cross-section of the FC, FE & FEE cylinders

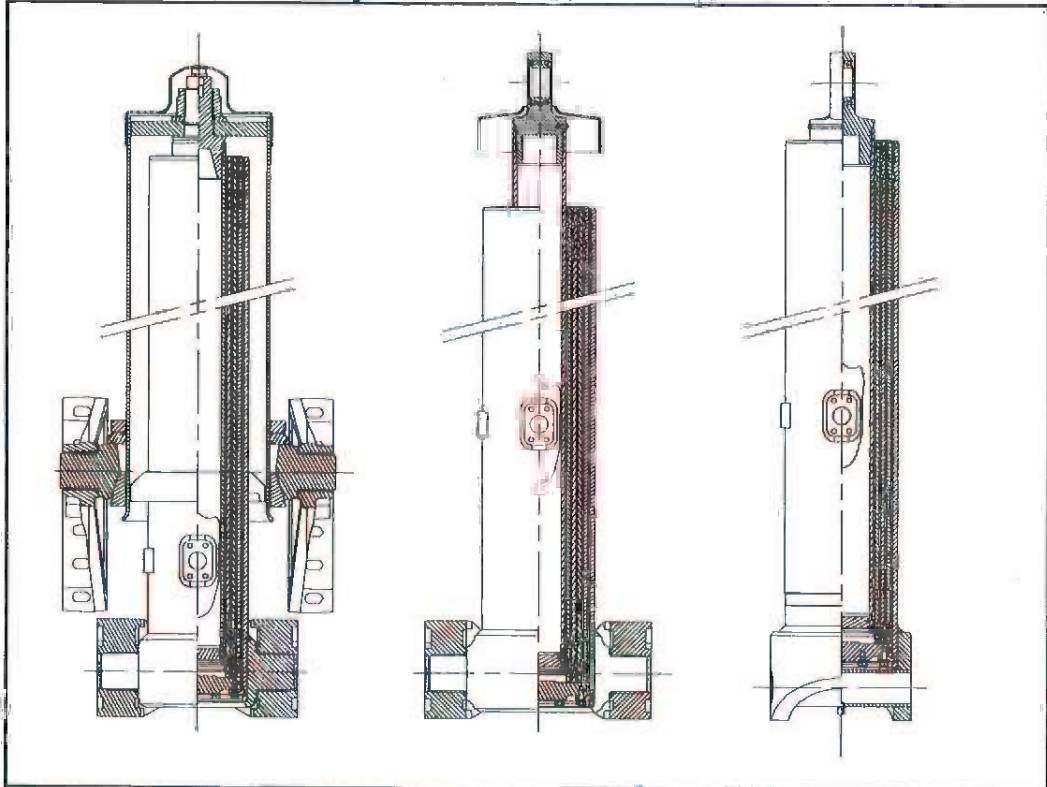

FIGURE 1: CROSS-SECTION OF THE FC, FE & FEE CYLINDERS

FE cylinder with gimbal

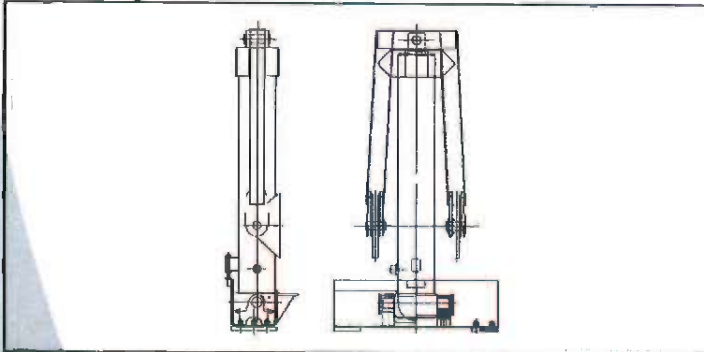

FIGURE 2 FE CYLINDER WITH GIMBAL

# Repair Instructions

## Front-End FC, FE and FEE type F.L.A.S.H.

Position of pack-set, sliders, stop ring and lift rings

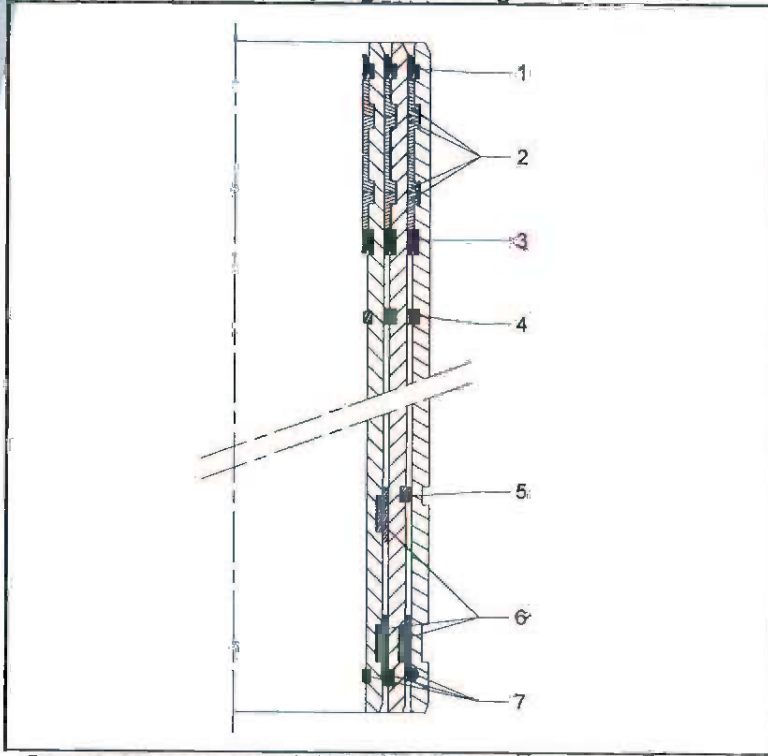

FIGURE 3: POSITION OF PACK SET, SLIDER RINGS, STOP RING AND LIFT RINGS.

Pack set consisting of:

- |   |              |     |  |
|---|--------------|-----|--|
| 1 | = wiper      | 5*  | = outer stop ring  |
| 2 | = wear rings | 6*  | = sliders  |
| 3 | = seal       | 7** | = lift ring (round for small, square for larger diameters) |
| 4 | = stop ring  |     |  |

\* Tubes with diameters 072, 091 & 129 have double sliders

Tubes with diameters 149, 169, 191 & 214 have one slider and one outer stop ring

\*\* Tubes with diameters 091, 129 & 149 have square lift rings

Tubes with diameters 169, 191 & 214 have round lift rings

### 3.1.2. Removing the cylinder from the vehicle

#### 1 Disconnection from the body

Where an FC cylinder is to be repaired, the main body of the cylinder can be removed from the truck, leaving the outer cover attached to the body. With the Gimbal type cylinder, it is possible to leave the gimbal attached to the body.

#### **Danger**

*Working under an unsupported tipper body is a danger to life.*

# Repair Instructions

## Front-End FC, FE and FEE type F.L.A.S.H.

Support the tipper body with a body prop using a rope or sling and a suitable lifting device, to prevent the cylinder from falling over. (Figure 34)

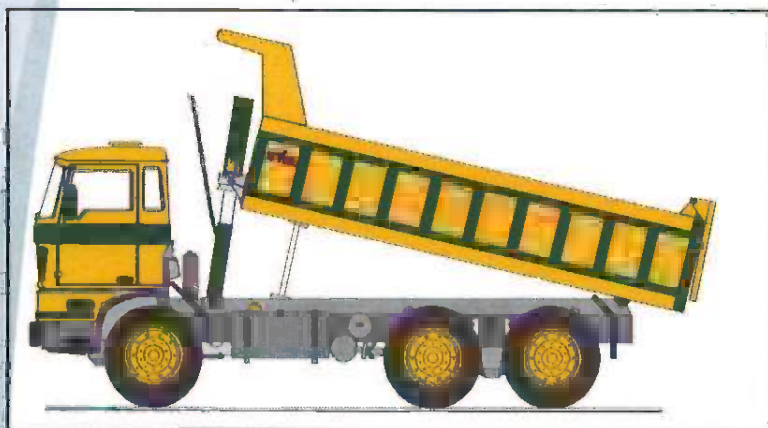

FIGURE 4: BODY SUPPORT AND LIFTING DEVICE

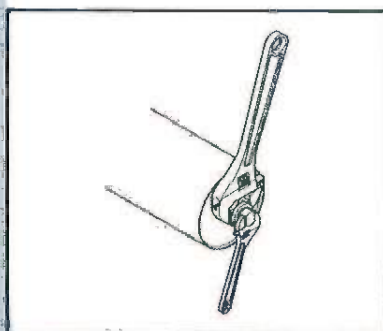

FIGURE 5

### 1. FC cylinder

Remove the top nut from the cylinder (Figure 5). Slowly raise the tipping body (using hydraulic system) until the first moving stage is visible.

Support the body and cylinder (Figure 4) and allow the cylinder to settle away from the cover.

### 2. FE cylinder

Secure the cylinder, using a rope or sling and a suitable lifting device, to prevent the cylinder from falling over.

Remove the pivot pin from the piston eye, the actual method

will depend on eye and top bracket. In general remove the split-pin and tap out the pivot pin. (Figure 6)

### 3. FE cylinder with gimbal

Raise the body (using hydraulic system) until the second moving stage is visible. Secure the gimbal to the tipper body using a rope or sling to prevent the gimbal from falling.

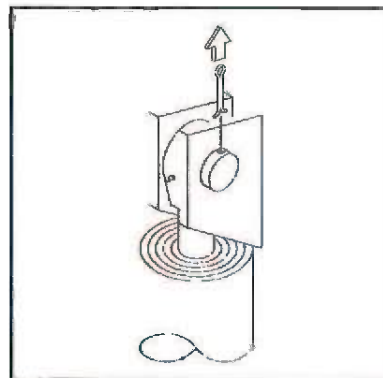

FIGURE 6

# Repair Instructions

## Front-End FC, FE and FEE type F.L.A.S.H.

Remove the securing bolt and top pin. (Figure 7)

*Tip*

*Never lift the body using the gimbal construction, as this will damage the cylinder*

Support the body and allow the cylinder to settle away from the gimbal.

### II Removing the cylinder from the chassis

Put the air control valve in the 'lower' position and allow the stages to settle to their rest position.

#### 1. FC and FE cylinder

Remove one of the trunnion brackets from the cradle or sub frame (Figure 8) and ease the cylinder from the other bracket.

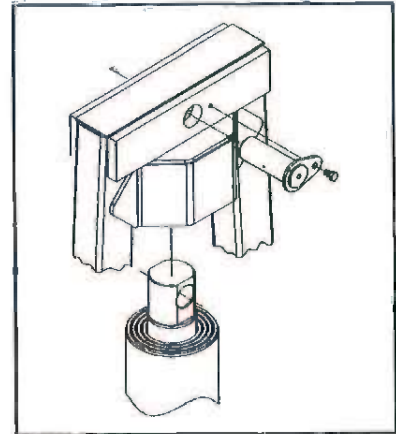

FIGURE 7

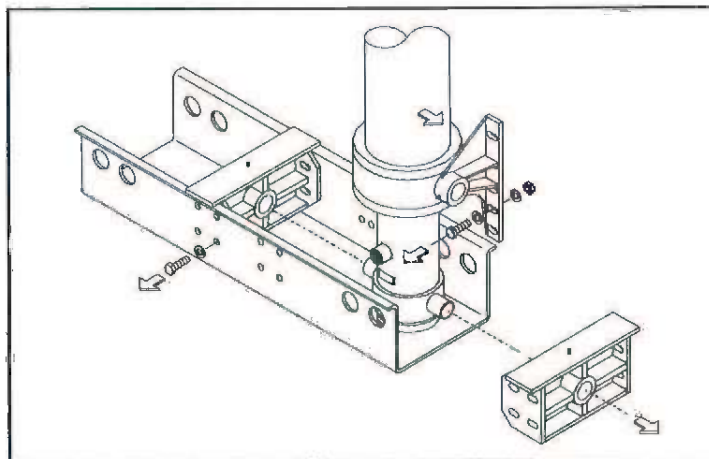

FIGURE 8: REMOVAL OF THE FC & FE CYLINDER



# Repair Instructions

## Front-End FC, FE and FEE type F.L.A.S.H.

### 2. Gimbal cylinder

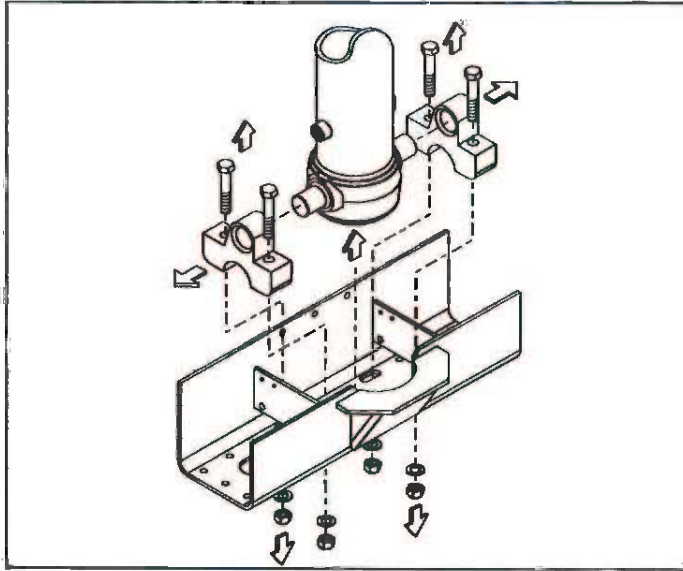

FIGURE 9 REMOVING THE CYLINDER FROM THE BRACKET CRADLE

Remove both of the trunnion brackets from the cradle.

*From this point the gimbal cylinder can be treated as a normal FE cylinder*

#### 3.1.3. Refitting the cylinder to the vehicle

After the cylinder has been reassembled, it can be re-fitted to the chassis. Refitting the cylinder to the vehicle is the same as removal but in reverse. Apply a thin layer of preservation grease (for example packset grease) on the trunnion pins prior to fitting the brackets.

For further information see mounting instructions for FC/FE cylinder.

#### 3.2. Dismantling the cylinder

Lay the cylinder flat on a clean bench with the oil inlet facing downward. Clamp securely to avoid damage and injuries (a "V" block arrangement is usually the best) and collect any waste oil.

## **Repair Instructions**

### **Front-End FC, FE and FEE type F.L.A.S.H.**

#### **3.2.1. Removing piston eye/head**

The F.L.A.S.H. series is standard equipped with a threaded piston eye/head. To lock the threading an oval pin with round head is hammered in a 6 mm round hole. This pin must be removed by drilling it out with a 5 or 6 mm drill. Then remove the eye as shown in Figure 10. Remove the piston through the bottom of the cylinder. After drilling make sure that burrs from the drilling operation are removed properly to prevent damage of the packset.

Remove the seal ring ("O" ring) from the threaded eye/head.

#### **3.2.2. Opening the base**

Use a ring spanner to remove the bolts from the bottom plate (3 or 6 depending on cylinder type) and remove the locking plates (Figure 11 & Figure 12.).

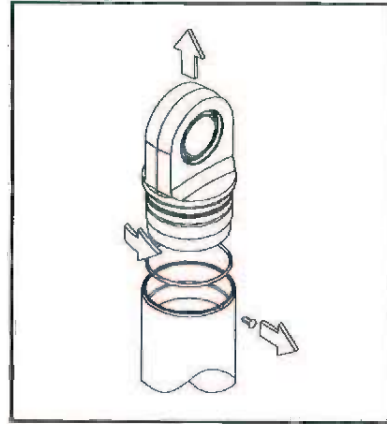

FIGURE 10

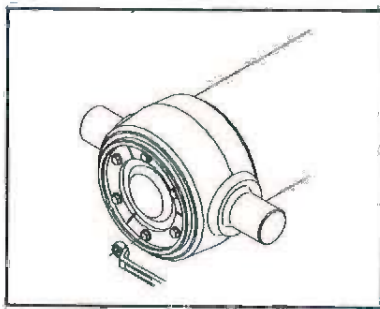

FIGURE 11

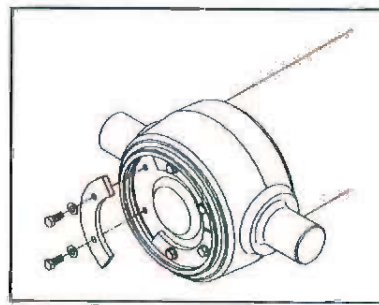

FIGURE 12

The bottom plate can now be removed by either:  
Using two bolts in the bottom plate to lever it out of the base tube. (Figure 14)

Or:

Strike the head of the piston with a soft-headed mallet or similar. If the piston eye/head is unscrewed, be careful not to damage the tube. This will push the bottom plate from the base tube. (Figure 13)

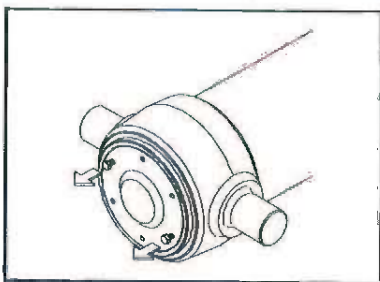

FIGURE 14

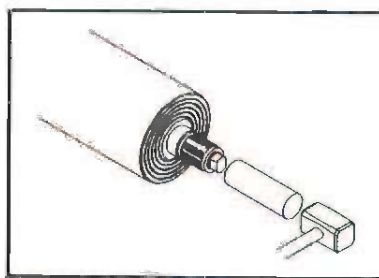

FIGURE 13

# Repair Instructions

## Front-End FC, FE and FEE type F.L.A.S.H.

Remove the seal from the bottom plate. (Figure 15)

### 3.2.3/ Removing the piston

Pistons of diameter 129 mm or less have two part sliders, these should be removed to avoid loss or damage. 149 mm pistons (or larger) have one piece sliders, these don't need to be removed.

Push the piston forward until the lift ring is visible at the inside diameter of the next stage (Figure 17).

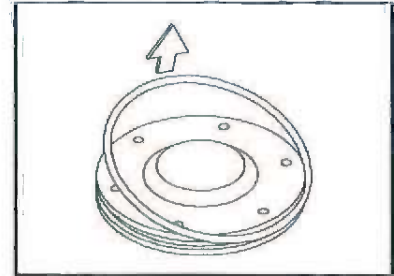

FIGURE 15

#### Warning

*The lift ring is mounted under tension, it may spring out and hit you in the face.*

Remove the lift ring by pushing the tip of a screwdriver under the ring at one end and levering the ring out. (Figure 18)

The piston can now be removed through the bottom of the cylinder (Figure 16).

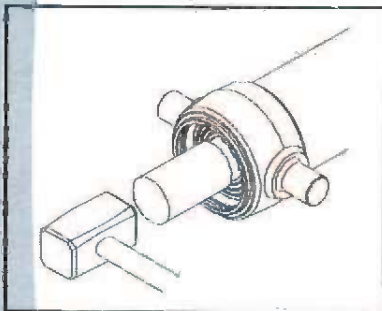

FIGURE 17

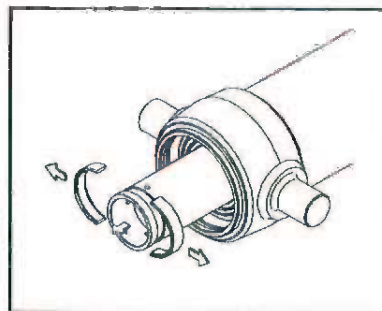

FIGURE 16

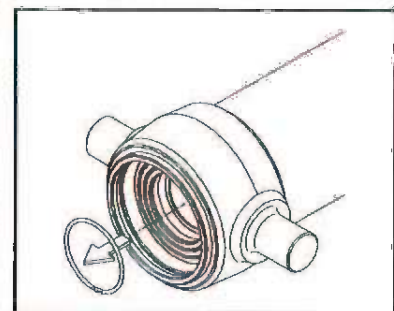

FIGURE 18

### 3.2.4. Removing the stages

#### Warning

*The stages must be placed on a clean surface to prevent scratches and other damage.*

*Never remove a stop ring, if it shows signs of damage the whole stage must be replaced.*

*The seals and wipers must not be re-used.*

Before a stage can be removed through the bottom of the cylinder, the lift ring of the next stage must be removed. Remove the lift ring in the same way as for the piston. The stage can then be removed through the bottom of the cylinder.

Subsequent stages can be removed in the same way.

## Repair Instructions

### Front-End FC, FE and FEE type F.L.A.S.H.

Remove the seal, wiper and wear rings from the internal grooves at the top of each stage (Figure 19).

*Tip*

*Do not remove the seals and wipers with a screwdriver or other sharp instrument as this may irreparably damage the grooves and cause leaks. Only the wear rings can be removed with a screwdriver.*

Clean each stage carefully and check each groove and the tube surface for any irregularities. Check also the sliders on each tube; if these are damaged, they should be replaced.

If the slider is damaged, check the stop ring in the subsequent tube for signs of damage or twisting.

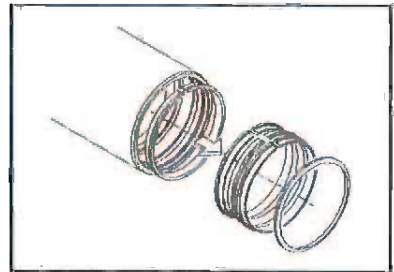

FIGURE 19

## **Repair Instructions**

### **Front-End FC, FE and FEE type F.L.A.S.H.**

# 4

### **Assembly**

*Step by step guide on how to replace the packset in each stage, replace the stages and piston, refitting of the piston eye (where applicable).*

*Finally refitting the bottom plate to close the cylinder, ready for reuse.*

- Replacing packset
- Replacing Stages
- Fitting piston eye/head
- Closing the cylinder (all types)

# Repair Instructions

## Front-End FC, FE and FEE type F.L.A.S.H.

### 4. Assembly

#### 4.1. Replacing packset

Clean each stage thoroughly and apply sufficient grease to the packset and the grooves (Figure 21). Put a new packset into each stage (Figure 20),

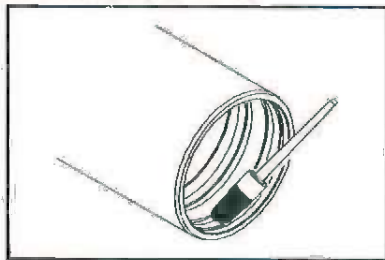

FIGURE 21

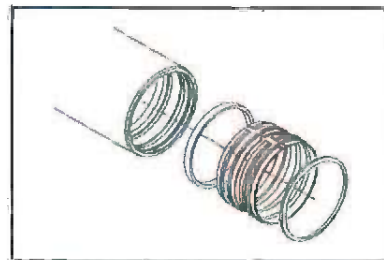

FIGURE 20

Starting with the seal (Figure 23), followed by the wear rings (Figure 22) and the wiper (Figure 24). See also Figure 3 page 11.

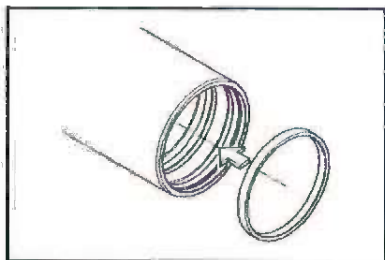

FIGURE 23

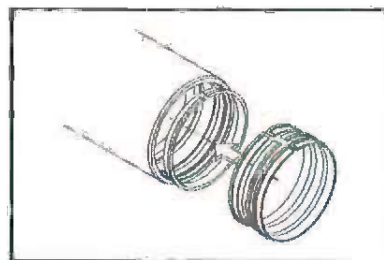

FIGURE 22

#### Caution

*Ensure that each of the rings are seated correctly in the grooves; incorrect fitting can cause seizure, leaks or damage.*

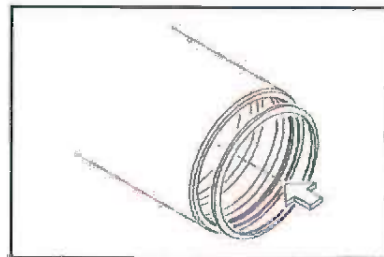

FIGURE 24

# Repair Instructions

## Front-End FC, FE and FEE type F.L.A.S.H.

### 4.2. Replacing Stages

Slide the first stage almost fully into the base tube, ensuring that the tube is not scratched when passing the stop ring (Figure 25 & Figure 26). Some resistance will occur when the tube enters the packset.

To prevent damage and ease assembly, special cones are available. See Table 1 page 26.

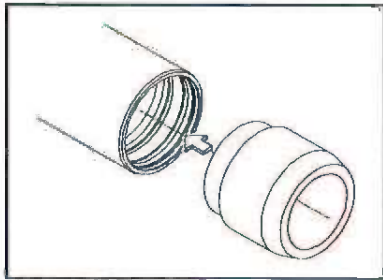

FIGURE 25.

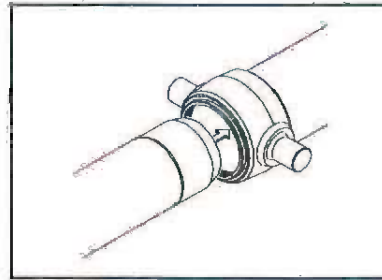

FIGURE 26.

Place the sliders and/or outer stop rings at the end of the stage (Figure 27); use enough grease at bottom inside of the tube to prevent scratches. Slide the tube further in to the base until the sliders are in the base tube.

Subsequent stages can be mounted in the same way.

After mounting a stage, fit the lift ring (Figure 28) in the previous inner (except cylinder base). See Figure 3 on page 11.

The piston is mounted in the reverse sequence to dismantling. Make sure that no sharp edges are at the top side that can damage the packset. For further assembly see point 3.2.4 page 16 for dismantling the cylinder.

#### Tip

*Make sure that the surface of the top end of the piston is smooth, especially around the old locking pin hole.*

*The sliders must be mounted with the flat side of the top slider facing upwards (not relevant for sliders 072-129). See Figure 3 on page 11.*

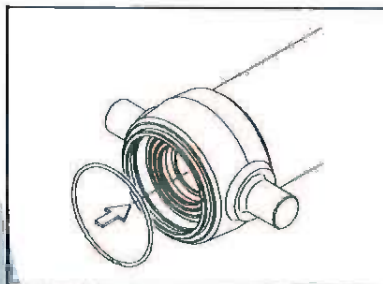

FIGURE 28

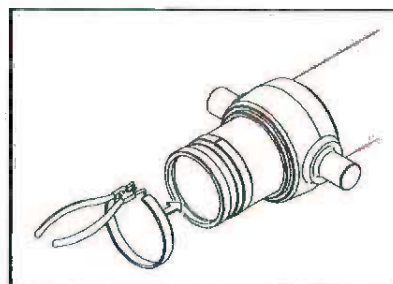

FIGURE 27

# Repair Instructions

## Front-End FC, FE and FEE type F.L.A.S.H.

### 4.3. Fitting piston eye/head

Fit a new "O" ring to the piston eye. Apply plenty of grease and screw the eye onto the piston. (Figure 29)

#### Warning

*Not fitting the locking pin is danger to life.*

*Fitting the eye onto the piston can be eased by applying copper grease to the screw thread.*

Make sure that the piston eye/head is firmly screwed into the piston tube. Use a hammer to be sure and check if there is absolutely no gap between piston eye/head and top end of the piston tube. Drill a new hole, 5,9-6,0 mm diameter, 16 mm deep, at least 60 degree rotated from the previous hole for the grooved locking pin.

Firmly hammer the locking pin in the new hole, apply locking agent (i.e. Loctite 242 or equivalent) before mounting. If during hammering the grooved pin is not causing substantial resistance, the diameter of the drilled hole is too big.

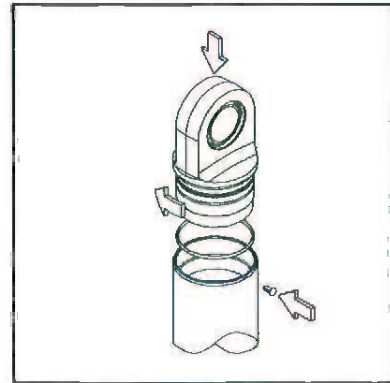

FIGURE 29

#### Warning

*Make sure eye/head is fully threaded into the piston*

*Make sure that diameter of the hole for the locking pin is not bigger then 6,0 mm*

*Do not reuse the old hole for locking pin*

### 4.4. Closing the cylinder (all types)

Fit a new seal to the bottom plate and slide the bottom plate into the base (Figure 30) use plenty of grease (Figure 31) to avoid damage to the seal.

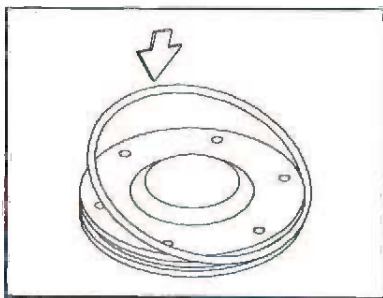

FIGURE 30

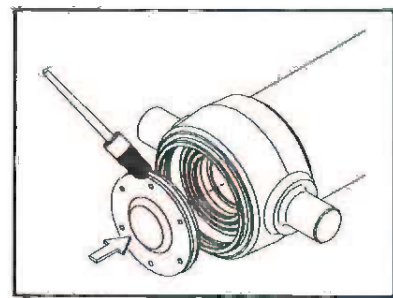

FIGURE 31



## **Repair Instructions**

### **Front-End FC, FE and FEE type F.L.A.S.H.**

Secure the bottom plate with the 3 locking plate (Figure 32 & Figure 33) using 2 new bolts and spring washers for each. See table 6.1.II page 26 for bolt torques.

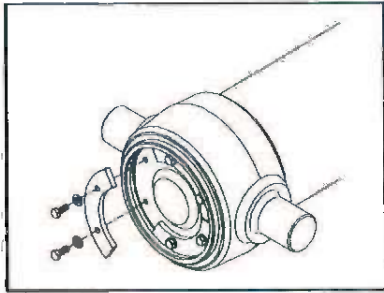

FIGURE 32

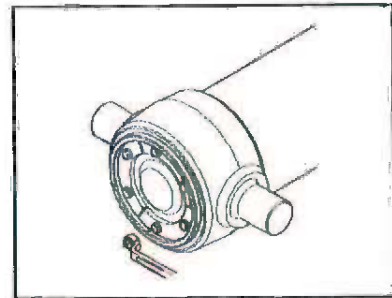

FIGURE 33

#### **Warning**

**The top nut on the outer cover must not be re-used.**

## **Repair Instructions**

### **Front-End FC, FE and FEE type F.L.A.S.H.**

# 5

### **Connecting and testing the cylinder**

*Once the repairs to the cylinder are complete it is ready to be replaced on the vehicle.*

*The hydraulics can then be reconnected and tested with a series of simple checks.*

*There is also details of the Hyva standard paint at the end of the chapter should the cylinder need repainting.*

- Connection of the hydraulic system
- Final Checks
- Painting the cylinder