



CS&CD SERIES PTOs

FOR 10 BOLT TYPE TRANSMISSIONS



CS41 SERIES

CLUTCH SHIFT PTO

When you need as much power as possible from an Allison 3000 or 4000 and Caterpillar CX transmission, the CS41 PTO delivers. The CS41 is designed to handle the extreme, heavy duty requirements of today's equipment, including digger derricks, refuse packers and fire trucks.

Made with the widest gears in the industry, finish ground for maximum strength, noise reduction and durability, the CS41 is rated from 490 to 600 lb.ft. and is available in 3 speed ratios. Output shaft options are available for the 1410 Series driveline and hydraulic pumps with SAE "C", SAE "B" 2 & 4 bolt with SAE "C" shaft or DIN 5462 connections.

A heavy duty internal clutch pack delivers smooth and positive engagement. Pressure lubrication is pre-plumbed. Remote solenoid activation is standard to allow clearance from chassis obstructions.

Two housing configurations are available to provide output shaft locations either high or low for either side of the transmission. This makes installation easier and better suited for today's confined chassis space.

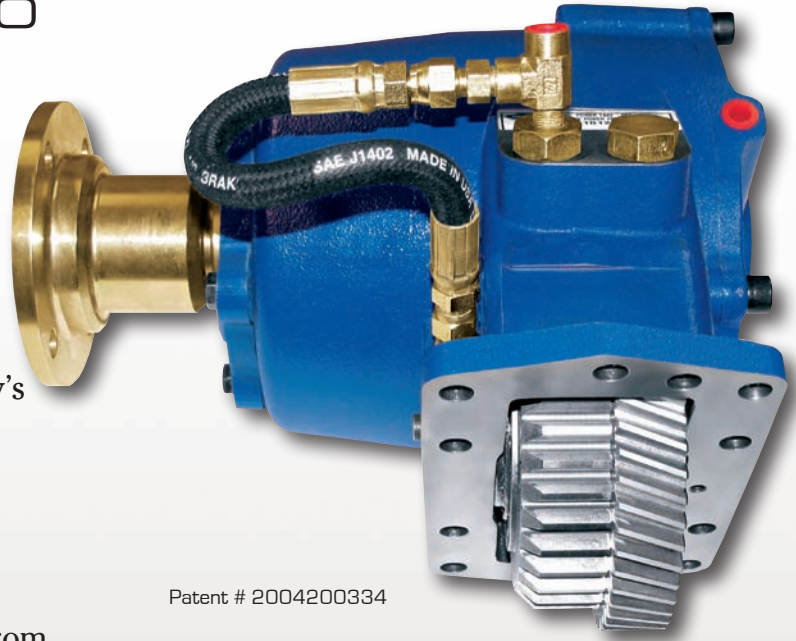

Patent # 2004200334

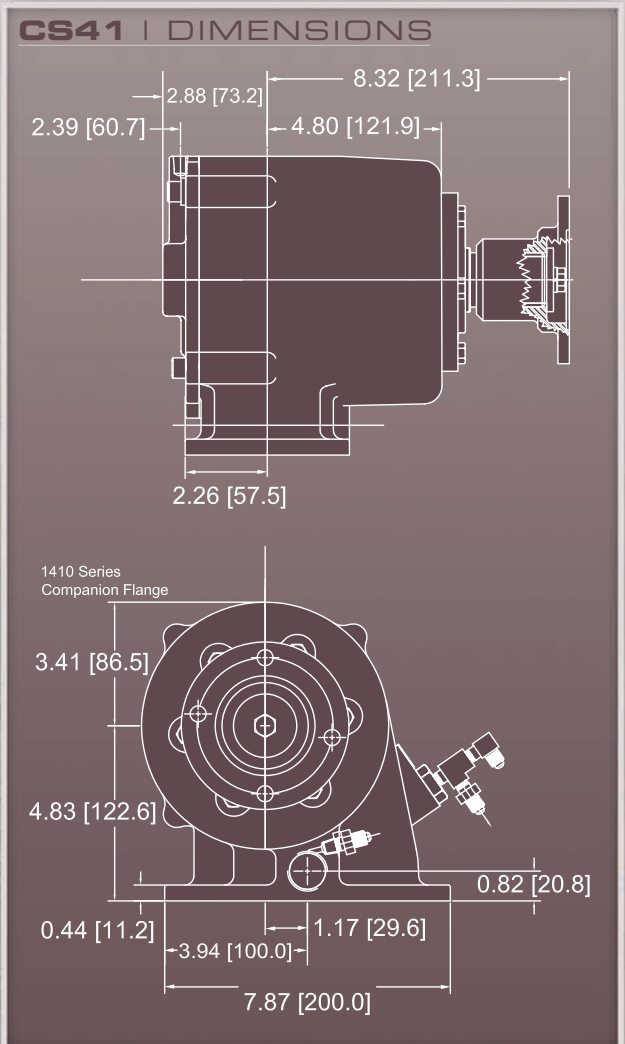

CS10 SERIES

CLUTCH SHIFT PTO

A versatile, heavy duty PTO for the Allison 3000 & 4000 and Caterpillar CX transmissions, the CS10 is the PTO designed to handle a wide range of heavy duty applications including dump bodies, utility, refuse, recovery and fire vehicles.

Offering large gears and a heavy duty housing, the CS10 is rated from 385 to 500 lb.ft. across the 5 available speed ratios. The location of the output shaft of the CS10 is designed around popular hydraulic pumps and has the ability to accept these pumps without the need to alter the Allison transmission case. The CS10 is standard with the 1-1/2" 10 spline (including the 1410 type companion flange) or is available with 1-1/4" round keyed output shaft. Also available are SAE "B" 2 & 4 bolt, SAE "C" 2 & 4 bolt, SAE "C" 2 bolt, and DIN 5462 hydraulic pump mounting flanges.

All CS10 & CS24 Series PTOs have the Muncie designed and patented integrated drag brake which assists in stopping the output shaft when the PTO is disengaged. The CS11 version has a remote mount solenoid activation valve for additional clearance of PTO during installation.

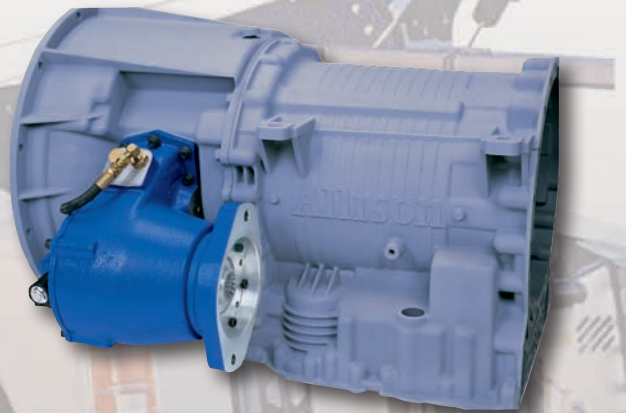
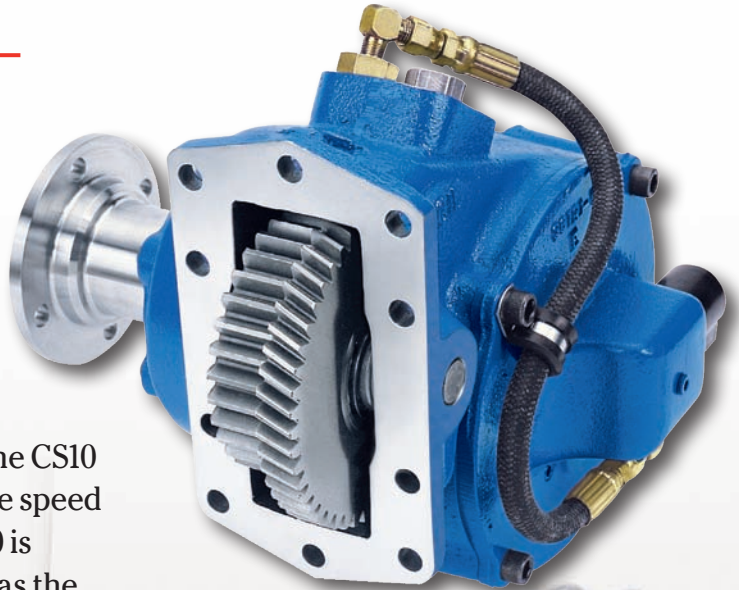

CS10 | DIMENSIONS

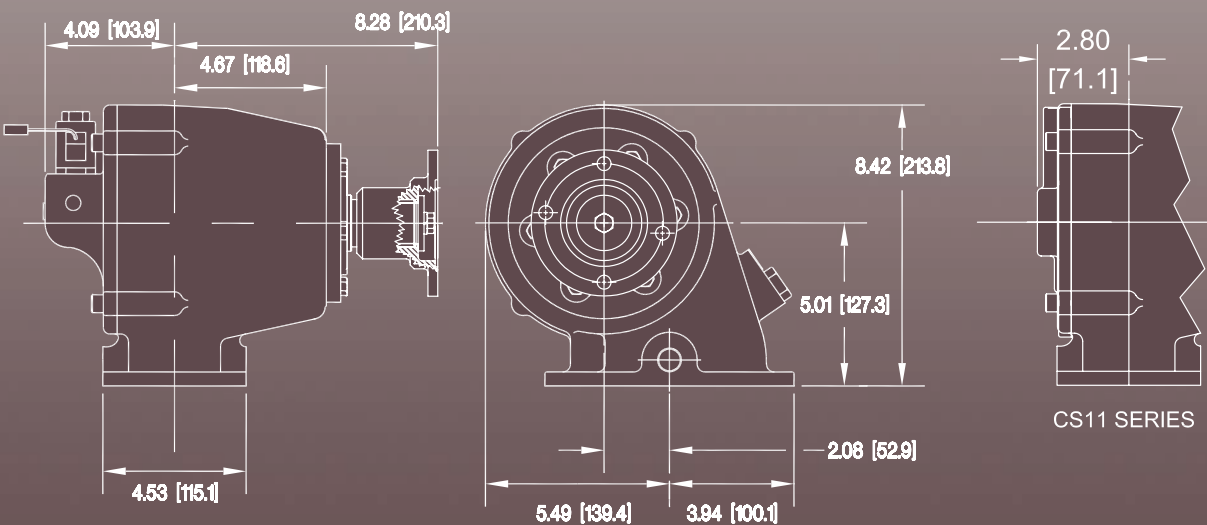

CS24 SERIES

CLUTCH SHIFT PTO

The Muncie CS24 Series PTO design is based on the same technology as the CS10. Though 20% smaller, the CS24 is still a heavy duty PTO for demanding applications like snow & ice removal, tandem & triple axle dumps, fuel haulers, aircraft refuelers, rear & side loader refuse vehicles, digger derricks, and aerial devices.

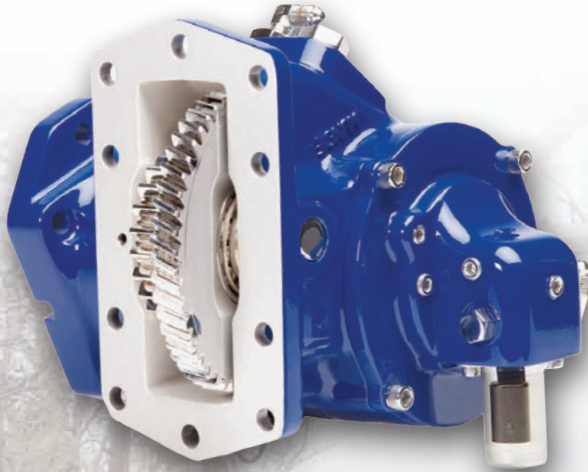

The CS24 Series PTO has torque ratings ranging from 200-325 lb.ft. and features 7 internal speed ratios. The highest speed ratio CS24, is ideal for utility vehicle applications to obtain high flow rates from smaller displacement hydraulic pumps at lower engine speeds.

It is available in 11 different output shaft types including the standard 1-1/4" round, SAE "B" either 2 bolt only or combination 2 & 4 bolt, SAE "A" 2 bolt, SAE "B-B" 2 & 4 bolt, and the non standard 4 bolt "G" option. Other output shaft options include a 1410 type companion flange, the DIN 100 companion flange and the DIN 5462 hydraulic mount. The hydraulic flanges are 360-degree rotatable with multiple mounting positions.

Two housing configurations are available to provide output shaft locations either high or low for either side of the transmission. This makes installation easier and better suited for today's confined chassis space. The CS25 version has a remotely mounted solenoid valve making it a more compact unit.

The Muncie HS24 is a similar PTO to the CS24 only it has a special housing for clearance on chassis with components near the PTO opening. This PTO is specifically designed for the Hino chassis with Allison World Transmission.

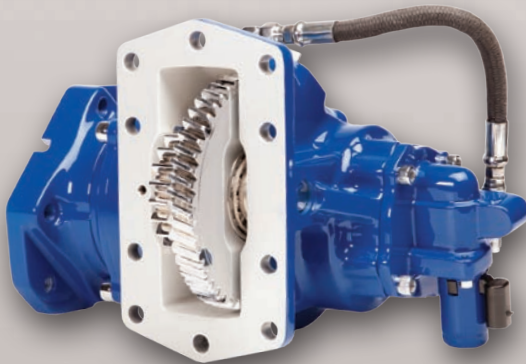

CS24 | DIMENSIONS

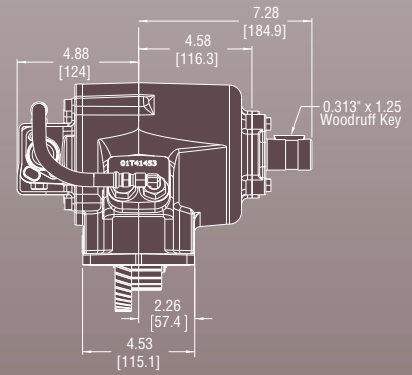

HS24 | DIMENSIONS

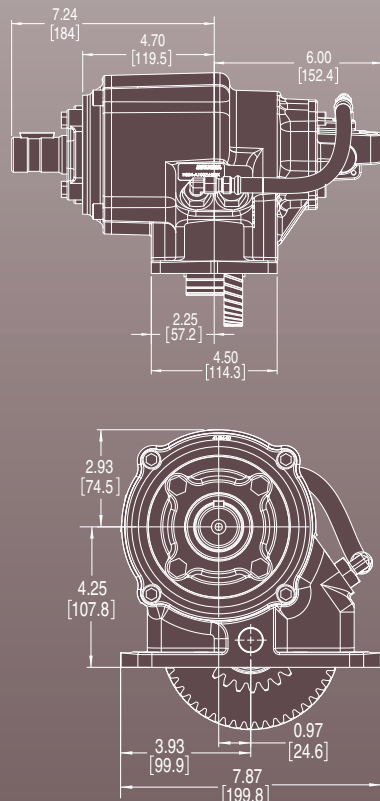

CS41 | PTO CONSTRUCTION

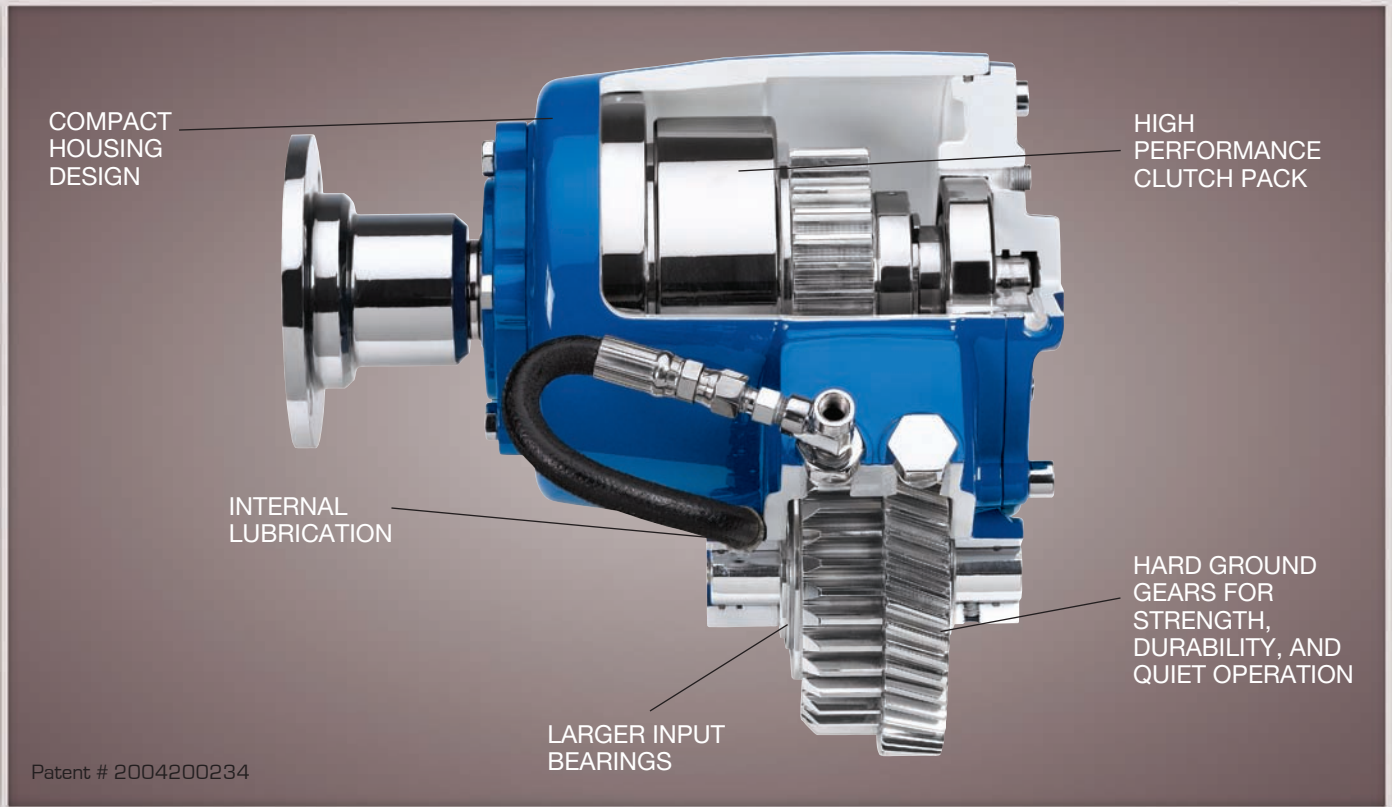

CS10, CS24 & HS24 | PTO CONSTRUCTION

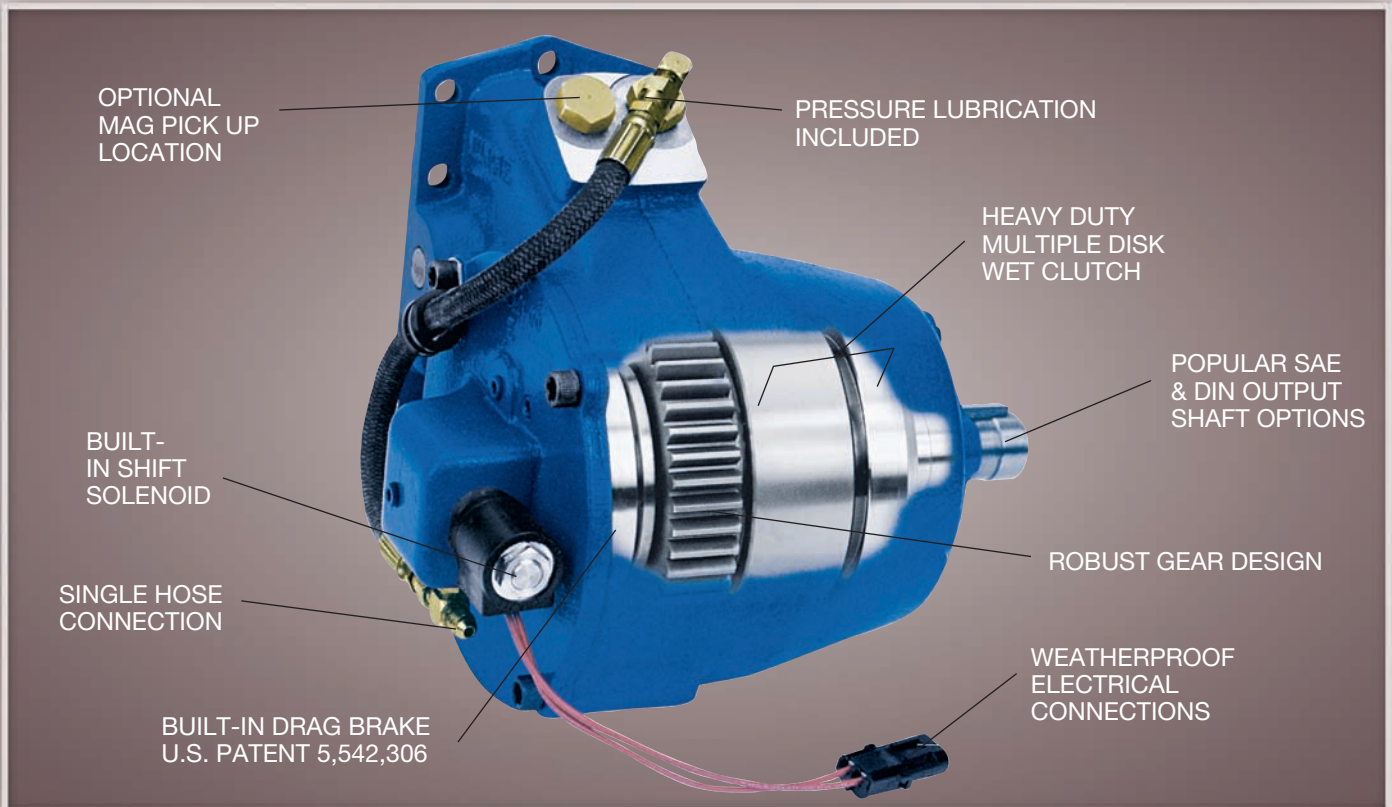

CD40 SERIES

CONSTANT DRIVE PTO

The Muncie CD40 Series PTO is designed for maximum PTO output torque for live engine driven equipment including refuse and cement mixers.

The Muncie CD40 Series constant drive PTO shares the same design technology as the shifttable CS41, including finish ground gearing and oversized bearing and shafts to provide maximum capacity for heavy duty applications.

The CD40 Series PTO is rated from 490 to 600 lb. ft. and is available with 5 output shaft options including fully rotatable hydraulic pump adapters. Available options are the popular hydraulic mounts, SAE "C" 2 bolt mount, SAE "B" 2 & 4 bolt with SAE "C" shaft, and the European DIN 5462 and DIN 100 companion flange.

The 1410 Series companion flange is the standard output. The CD Series PTO is available in 2 speed ratios and two housing arrangements to provide shaft locations either high or low for either side of the transmission.

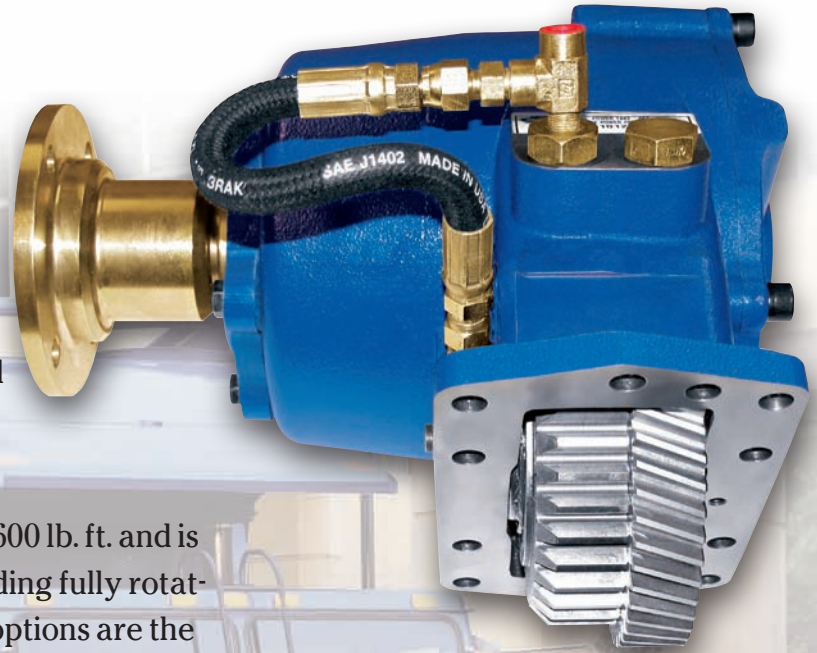

CD40 | DIMENSIONS

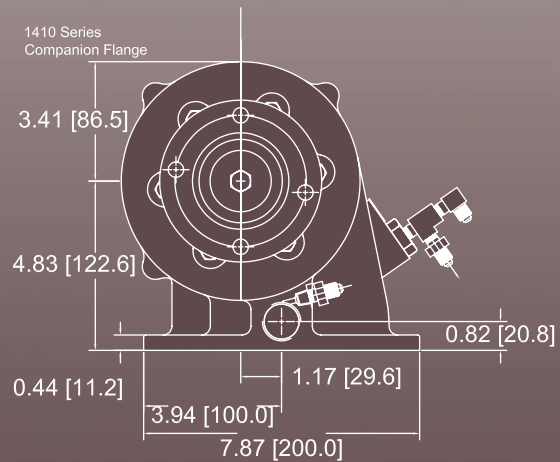
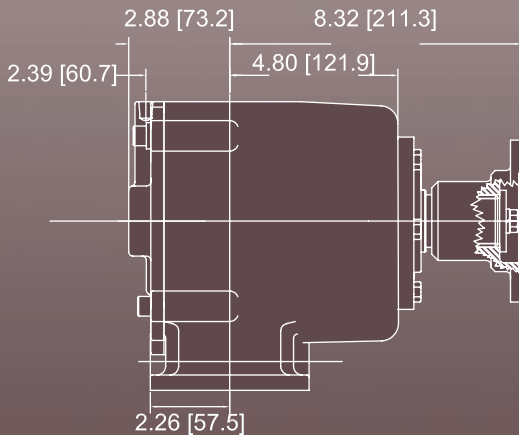

CD10 SERIES

CONSTANT DRIVE PTO

The Muncie CD10 Series PTO is designed to replace front mounted, engine driven systems typically used on refuse collection trucks and snow & ice control equipment.

The CD10 Series PTO is also ideal for load sense pump systems such as Muncie's V-Series variable displacement piston pump.

The Muncie CD10 Series constant drive PTO provides ample capacity for heavy duty applications without obstructing service areas of the truck engine and cooling system.

The CD10 Series PTO is rated from 225 to 400 lb. ft. with speeds to 2500 RPM and available with 10 output shaft options including fully rotatable hydraulic pump adapters. Available options are the popular hydraulic mounts, SAE "C" 2 bolt mount, an SAE "B" 2 & 4 bolt, SAE "B-B" 2 & 4 bolt, SAE "B" 2 & 4 bolt with SAE "C" shaft, SAE "A" 2 bolt and the European DIN 5462 and DIN 100 companion flange. The 1410 Series companion flange is the standard output and the 1-1/4" round output shaft is available for drive shaft installations.

The CD10 Series PTO is available in 7 speed ratios which makes it easy to select the correct PTO for your application.

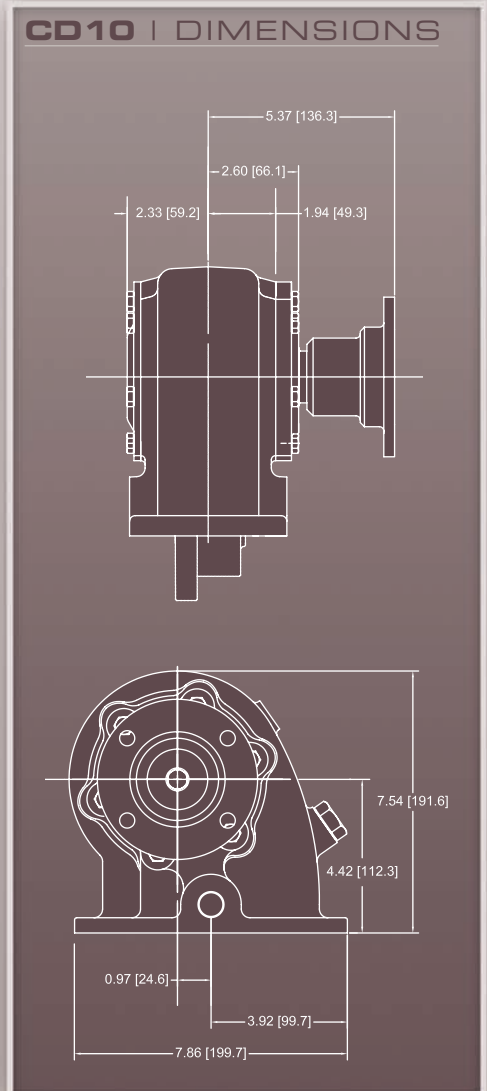
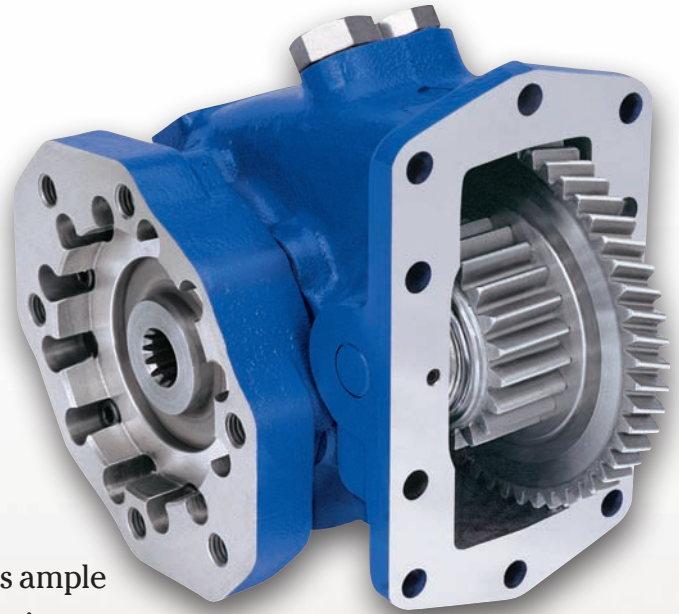

CLUTCHSHIFT

MODEL COMPARISON

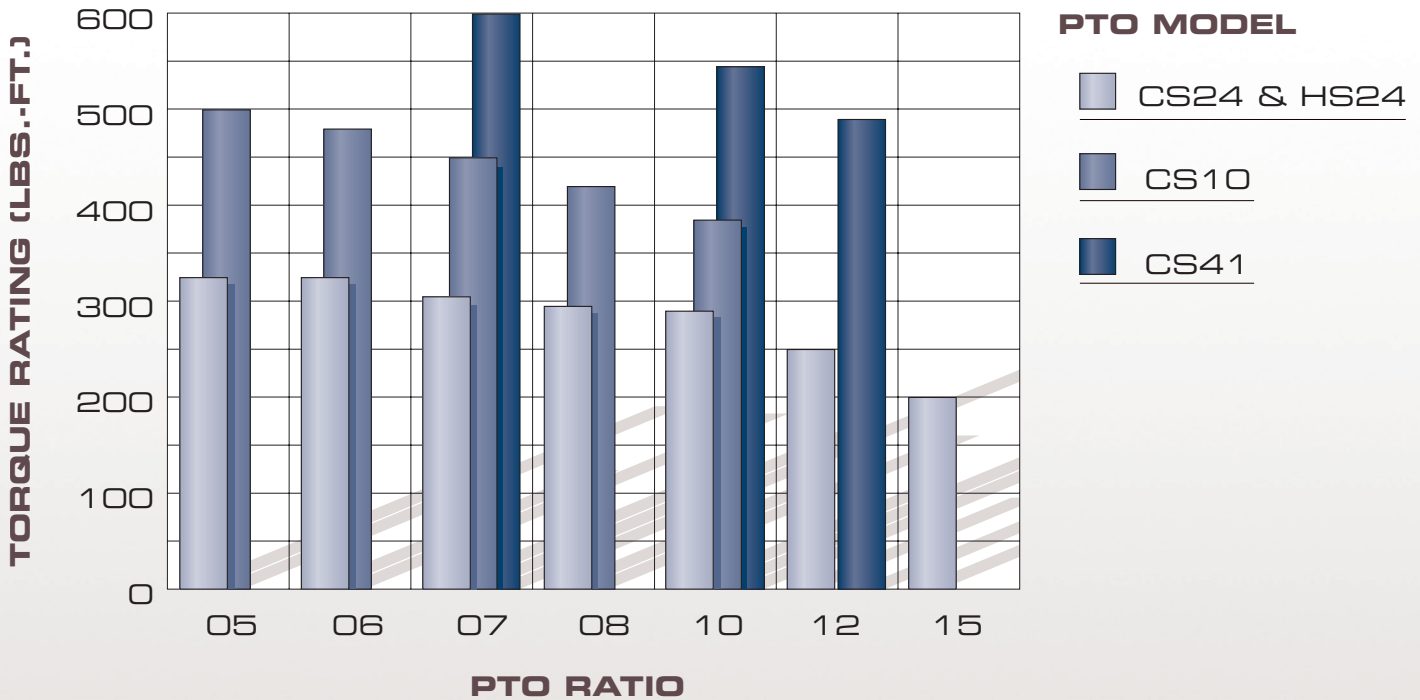

CLUTCH SHIFT PTO MODEL NUMBER CONSTRUCTION

CS 24 - A10 08 - H 1 C X

PTO Type

Clutch Shift — CS
— HS Low Profile

Mounting

10 Bolt Mount
10, 24
11, 215, 41 (remote shift solenoid valve)

Transmission CS Gear Data

Allison 10.16P RH — A10

Speed Ratio

CS24		HS24
05 — .55:1	10 — .97:1	06 — .56:1
06 — .64:1	12 — 1.19:1	07 — .70:1
07 — .74:1	15 — 1.47:1	09 — .87:1
08 — .84:1		12 — 1.15:1

CS10

05 — .55:1	08 — .84:1	07 — .64:1
06 — .64:1	10 — .97:1	10 — .97:1
07 — .74:1		12 — 1.19:1

Shifter Type

12V Elec/Hyd — H
24V Elec/Hyd — J

Special Feature

X — None (Pressure Lube Std. on all Units)
A — SP: SAE-B for Parker Sculpted Piston Pump (P-Shaft-Opt) CS24
B — 48" Hose Kit
D — Pulse Generator & EOS-111
U — Pulse Generator
3 — 17" Lube Hose Kit
4 — Lube Hose Delete

Output Type

B — 1-1/4" Round 5/16KW CS24, CS10, HS24
C — 1410 Companion Flange
D — SAE "B" 2 & 4 Bolt CS10
E — SAE "B" 2 & 4 Bolt CS10, CS41
G — Special CS20
I — DIN 5462
K — SAE "B" 2 & 4 Bolt CS24, HS24
P — SAE "BB" 2 & 4 Bolt CS10, CS24
Q — SAE "A" 2 Bolt CS24, HS24
S — SAE "B" 2 Bolt CS10, CS24
T — SAE "A" 2 Bolt 3/4" 11T CS24
Y — SAE "C" 2 Bolt CS10, CS41
Z — SAE "B" 2 & 4 Bolt SAE "C" Shaft
2 — DIN100 Companion Flange
6 — SAE "B" 2 Bolt CS24, HS24

Assembly Arrangement

1 or 3

CONSTANTDRIVE

MODEL COMPARISON

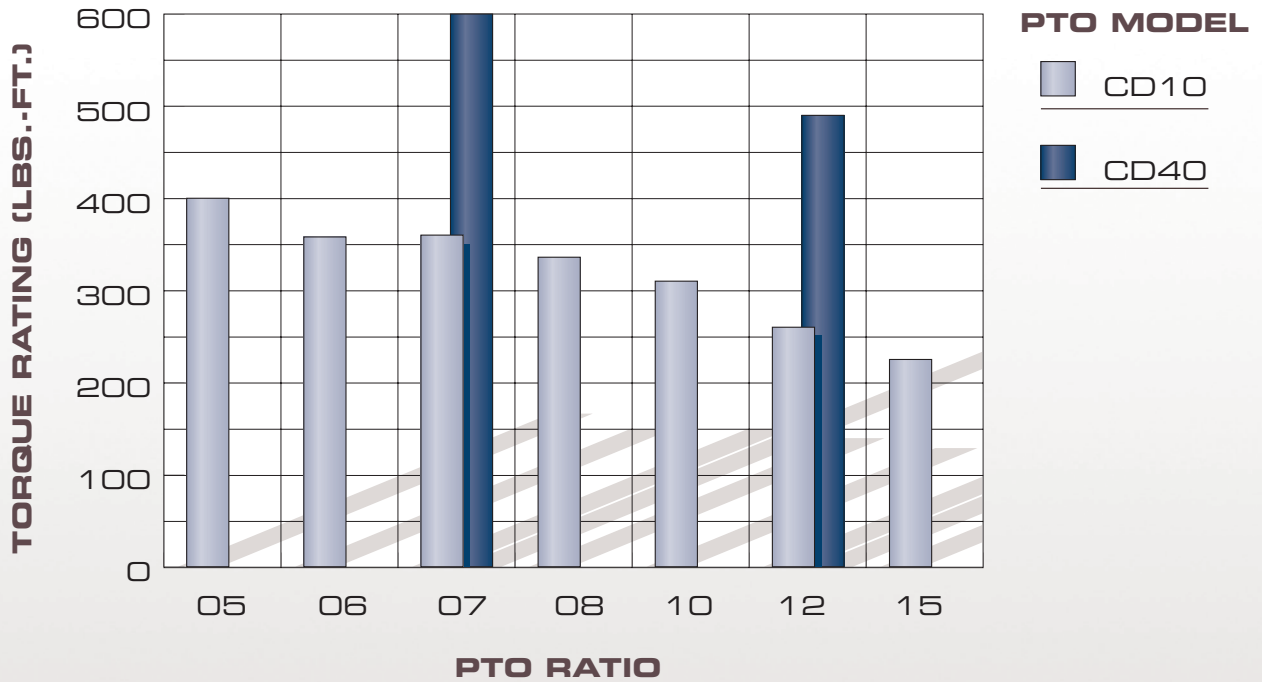

CONSTANT DRIVE PTO MODEL NUMBER CONSTRUCTION

CD 10 - A10 08 - M 1 C X

PTO Type

Constant Mesh — CD

Mounting

10 Bolt Mount
10, 40

Trans.

Allison

CS Gear Data

10.16P RH — A10

Speed Ratio

CD10

05 — .55:1 08 — .84:1
06 — .64:1 10 — .97:1
07 — .74:1 12 — 1.19:1
 15 — 1.47:1

CD40

07 — .64:1
12 — 1.19:1

Shifter Type

Constant Mesh — M

Special Feature

- X — None (Pressure Lube Std. on all Units)
- A — SP: SAE-B for Parker Sculpted Piston Pump (P-Shaft-Opt) CD10
- B — 48" Hose Kit
- G — Greaseable Output CD10
- 3 — 17" Lube Hose Kit
- 4 — Lube Hose Delete

Output Type

- B — 1-1/4" Round 5/16KW CD10
- C — 1410 Companion Flange
- D — SAE "B" 2 & 4 Bolt CD10
- E — SAE "C" 2 & 4 Bolt CD40
- I — DIN 5462
- P — SAE "BB" 2 & 4 Bolt CD10
- Q — SAE "A" 2 Bolt CD10
- R — SAE "A" 2 Bolt CD10
- S — SAE "B" 2 Bolt CD10
- Y — SAE "C" 2 Bolt CD10
- Z — SAE "B" 2 & 4 Bolt SAE "C" Shaft
- 2 — DIN100 Companion Flange

Assembly Arrangement

1 or 3



SHAFT EXTENSIONS



Patent # 6263749

PRODUCT FEATURES

- Developed in cooperation with Allison Transmissions.
- Direct mount large gear or piston type hydraulic pumps.
- Eliminates the driveline and driveline maintenance while reducing installation time and exposure to moving parts.
- Extended Shaft options are available for CD10 Series Heavy Duty Constant Mesh or CS20 & CS10 Clutch Shift PTOs.
- SAE “B”, SAE “B-B”, SAE “C” and DIN 5462 outputs.
- Perfect for Solid Waste, Snow and Ice Control, Utility Equipment dump bodies and many other applications.

1. Transmission must have rear support installed as supplied by the vehicle manufacturer.
 2. Allison 4000 Series: ES not currently available for the 7 speed HD4070 transmission. Not currently available for any 4000 retarder or units with rear-mounted oil coolers.
 3. All ES Kits are for shaft low PTO arrangements. “3” on left side and “1” on right side.

Muncie’s PTO shaft extensions for the Allison 3000 & 4000 Series transmission provide easier hydraulic pump installation by moving the hydraulic pump mount to the rear of the transmission. Shaft Extensions are available for most Allison 3000 & 4000 Series transmission² applications and popular pump mounts.

See Footnotes 1,2 & 3.

CD10 SERIES PTO			
LEFT SIDE OPENING	OUTPUT		RIGHT SIDE OPENING
CD10-A10**-M3ZX	ALLISON 3000 (MD) ALLI-5		CD10-A10**-M1ZX
49TA4125A	SAE B	2-4 Bolt	49TA4135A
49TA4126A	SAE B-B	2-4 Bolt	49TA4134A
49TA4127A	SAE C	2 Bolt	49TA4133A
49TA4999A	SAE C	2-4 Bolt	49TA5000A
49TA4128A	DIN 5462	4 Bolt	49TA4137A
49TA4450A	SAE B 2-4 Bolt w/SAE C SHAFT		49TA4451A
CD10-A10**-M3ZX	ALLISON 4000 (HD²) ALLI-6		CD10-A10**-M1ZX
49TA4132A	SAE B	2-4 Bolt	N/A
49TA4129A	SAE B-B	2-4 Bolt	N/A
49TA4130A	SAE C	2 Bolt	N/A
49TA4941A	SAE C	2-4 Bolt	N/A
49TA4131A	DIN 5462	4 Bolt	N/A
49TA4432A	SAE B 2-4 Bolt w/SAE C SHAFT		N/A
CS20 SERIES PTO			
CS20-A10**-H3IX	ALLISON 3000 (MD) ALLI-5		CS20-A10**-H1IX
49TA4692A	SAE B	2-4 Bolt	49TA4694A
49TA4698A	SAE B-B	2-4 Bolt	49TA4699A
49TA4788A	SAE C	2 Bolt	49TA4789A
49TA5001A	SAE C	2-4 Bolt	49TA5002A
49TA4896A	DIN5462	2 Bolt	49TA4897A
49TA4838A	SAE B 2-4 Bolt w/SAE C SHAFT		49TA4839A
CS20-A10**-H3IX	ALLISON 4000 (HD²) ALLI-6		CS20-A10**-H1IX
49TA4833A	SAE B	2-4 Bolt	N/A
49TA4834A	SAE B-B	2-4 Bolt	N/A
49TA4835A	SAE C	2 Bolt	N/A
49TA5003A	SAE C	2-4 Bolt	N/A
49TA4898A	DIN5462	4-Bolt	N/A
49TA4840A	SAE B 2-4 Bolt w/SAE C SHAFT		N/A
CS20-A10**-H3IX	ALLISON 3000 (MD) ALLI-10 (83T DRIVE GEAR)		CS20-A10**-H1IX
49TA4841A	SAE B	2-4 Bolt	N/A
CS10 SERIES PTO			
CS10-A10**-H3ZX	ALLISON 3000 (MD) ALLI-5		CS10-A10**-H1ZX
49TA4495A	SAE B-B	2-4 Bolt	N/A
49TA4506A	SAE C	2-Bolt	N/A
49TA4837A	SAE C	2-4 Bolt	N/A
CS41 SERIES PTO			
CS41-A10**-H3ZX	ALLISON 4000 (HD²) ALLI-6		CS41-A10**-H1ZX
49TA4877A	SAE C	2-Bolt	N/A
49TA5004A	SAE C	2-4 Bolt	N/A
49TA4880A	DIN5462	4-Bolt	N/A
49TA4881A	SAE B 2-4 Bolt w/SAE C SHAFT		N/A



CD10 | Shaft Extension (3000 LEFT SIDE)

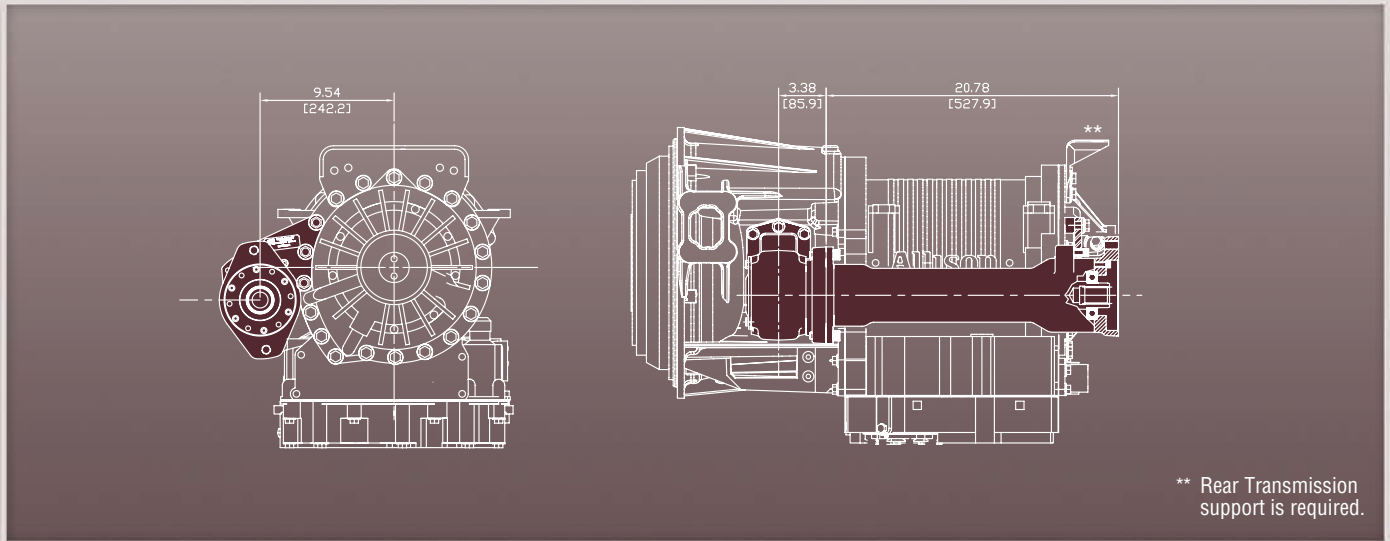

CS20 | Shaft Extension (3000 & 4000 LEFT SIDE)

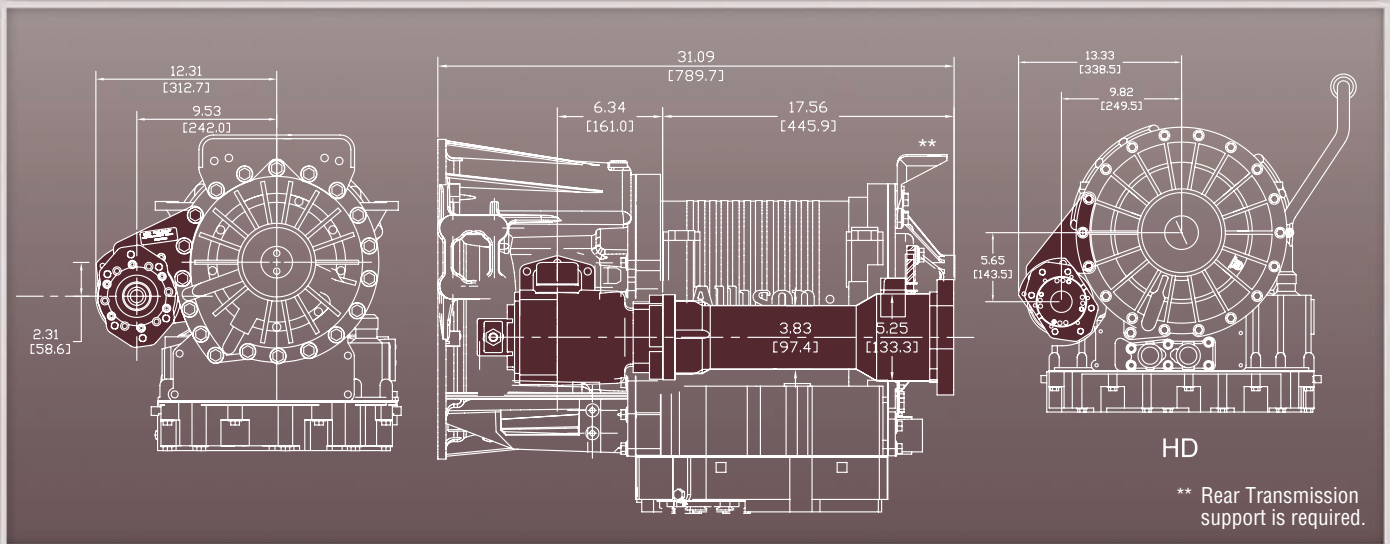

CS10 | Shaft Extension (3000 LEFT SIDE)

CS41 | (4000 LEFT SIDE)

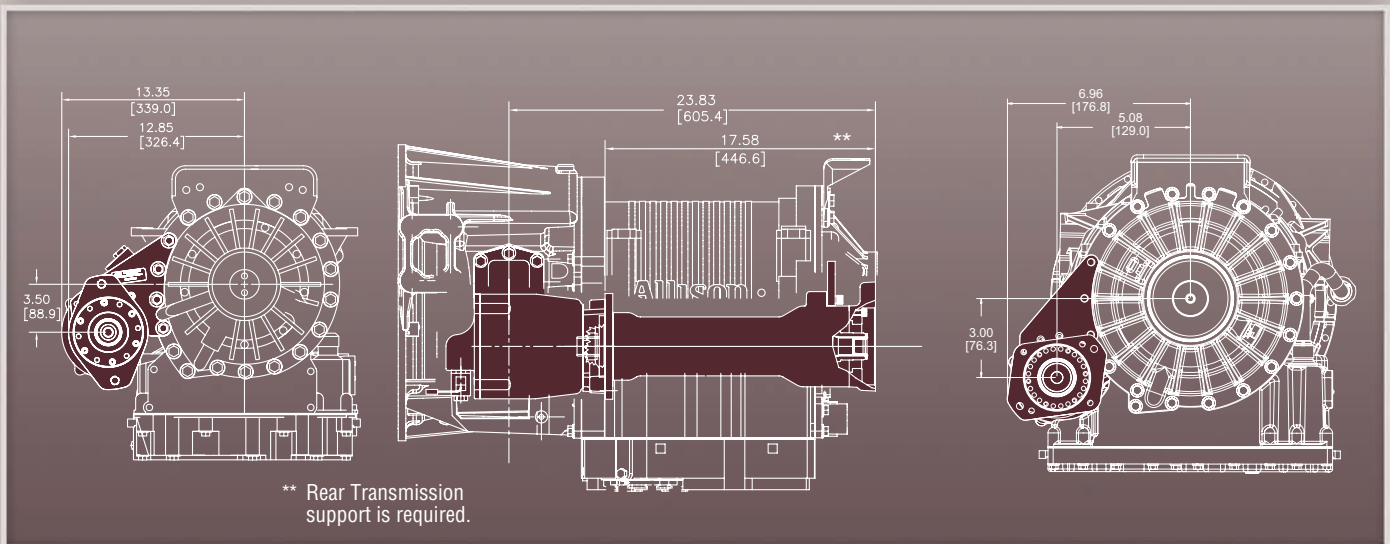

POWER TAKE-OFF WARRANTY

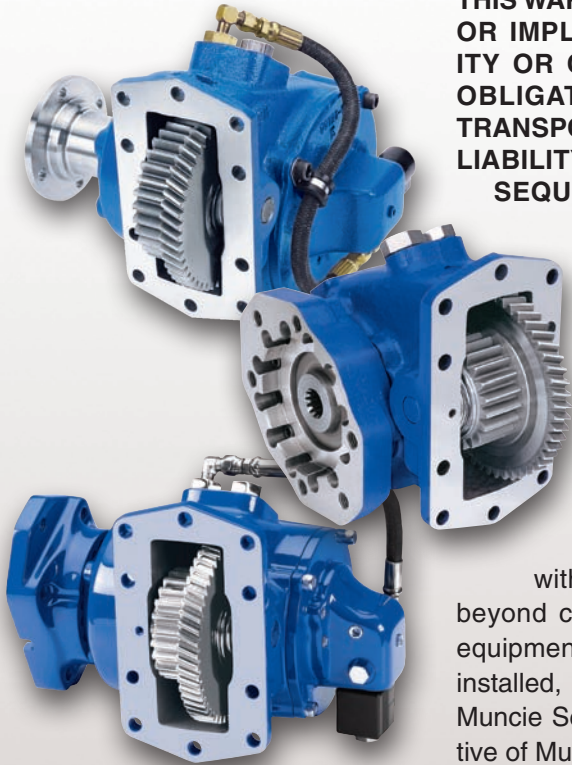

The Muncie CS10, CS20, CS41, CD10 and CD40 Series Power Take-Offs are warranted to be free of defects in material or workmanship and to meet Muncie's standard written specifications at the time of sale. Muncie's obligation and liability under this warranty is expressly limited to repairing or replacing, at Muncie's option, within two years after date of original installation any defective part or parts or any product not meeting the specifications.

THIS WARRANTY IS IN LIEU OF ALL OTHER WARRANTIES, EXPRESSED OR IMPLIED. MUNCIE MAKES NO WARRANTY OF MERCHANTABILITY OR OF FITNESS FOR ANY PARTICULAR PURPOSE. MUNCIE'S OBLIGATION UNDER THIS WARRANTY SHALL NOT INCLUDE ANY TRANSPORTATION CHARGES OR COSTS OF INSTALLATION OR ANY LIABILITY FOR DIRECT, INDIRECT, SPECIAL, INCIDENTAL, OR CONSEQUENTIAL DAMAGES OR DELAY. THE REMEDIES SET FORTH HEREIN ARE EXCLUSIVE, AND MUNCIE'S LIABILITY WITH RESPECT TO ANY CONTRACT OR SALE OR ANYTHING DONE IN CONNECTION THEREWITH, WHETHER IN CONTRACT, IN TORT, UNDER ANY WARRANTY, OR OTHERWISE, SHALL NOT, EXCEPT AS EXPRESSLY PROVIDED HEREIN, EXCEED THE PRICE OF THE PRODUCT OR PART ON WHICH SUCH LIABILITY IS BASED.

If requested by Muncie, products or parts for which a warranty claim is made are to be returned transportation prepaid to a Muncie Service Center. Any installation or use not in accordance with catalog or package instructions, other improper use, operation beyond capacity, substitution of parts not approved by Muncie, use with equipment other than the equipment on which the Power Take-Off is first installed, or alteration or repair made to the Power Take-Off other than at a Muncie Service Center, shall void this warranty. No employee or representative of Muncie is authorized to change this warranty in any way or to grant any other warranty.

Distributed By:



MP98-04 (Rev. 10-12) Printed in the U.S.A.
© Muncie Power Products, Inc. 2012

Muncie Power Products, Inc. Member of the Interpump Hydraulics Group
General Offices and Distribution Center • P.O. Box 548 • Muncie, IN 47308-0548
(765) 284-7721 • FAX (765) 284-6991 • E-mail info@munciepower.com
Web site <http://www.munciepower.com>

Drive Products, Exclusive Agents for Canada, ISO Certified by an Accredited Registrar

