

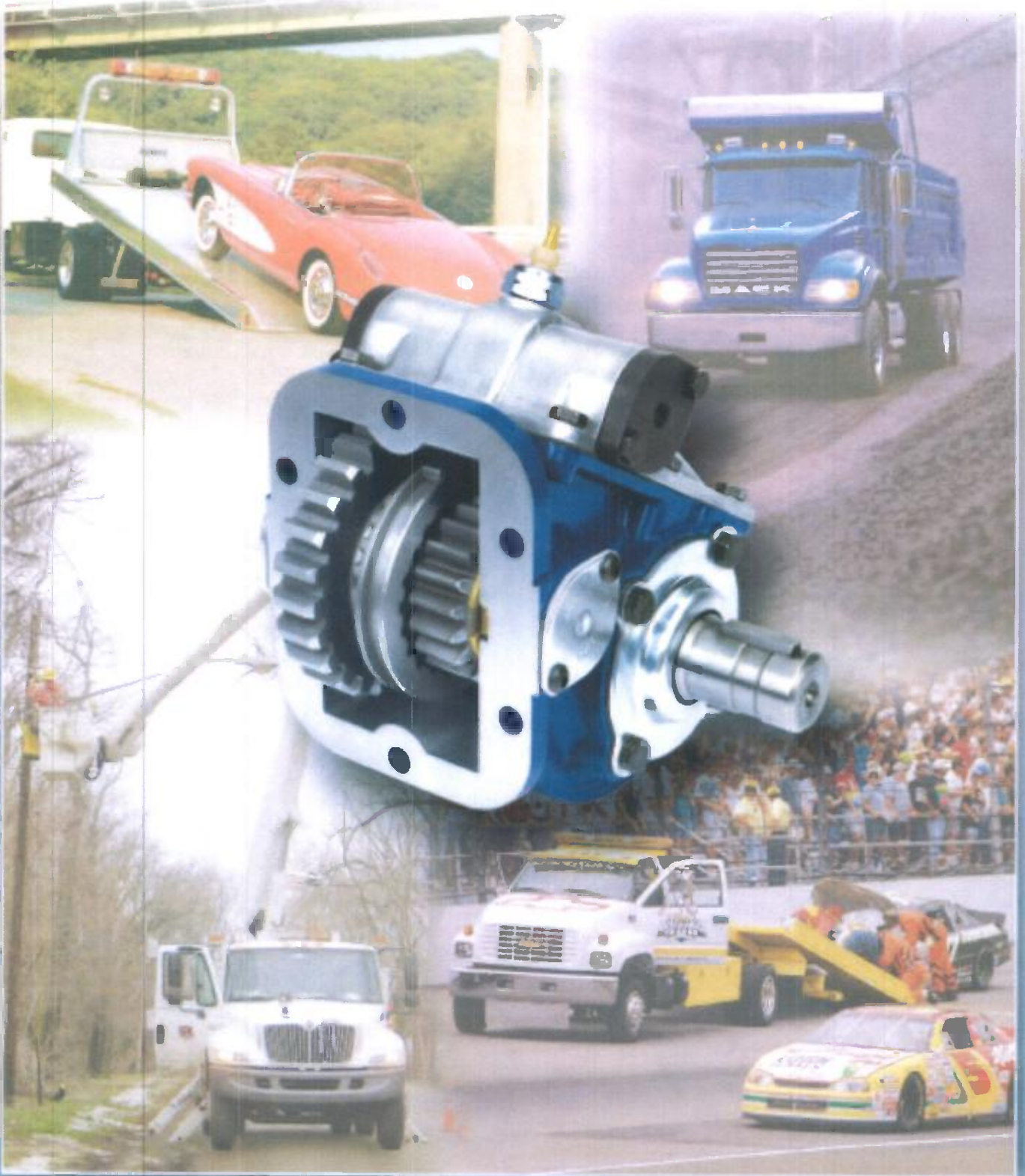

TG SERIES

POWER TAKE OFF



MUNCIE TG SERIES PTO SYSTEM

Versatility to meet today's ever changing demands. The TG Series PTO allows you to cover a wide variety of applications with thousands of assembly combination choices all within the same compact PTO series.

- Over 250,000 assembly combination possibilities
- Available in six or eight bolt housings
- Torque ratings from 175 to 285 lb-ft intermittent
- Horsepower ratings from 33 to 54 at 1000 RPM
- Over 75 easily interchangeable input gears
- 19 output options including 15 hydraulic pump mounts with 3 being externally greaseable
- 7 shifter options
- Reduced inventory cost
- Easily assembled or converted without special tools
- Die cast aluminum housing reduces overall weight while providing increased sound and heat diffusion and high impact resistance
- Constant engagement with the transmission gear eliminates damage from gear clashing
- Reduced envelope size decreases interference issues
- Superior bearing and gear design profile for quiet operation

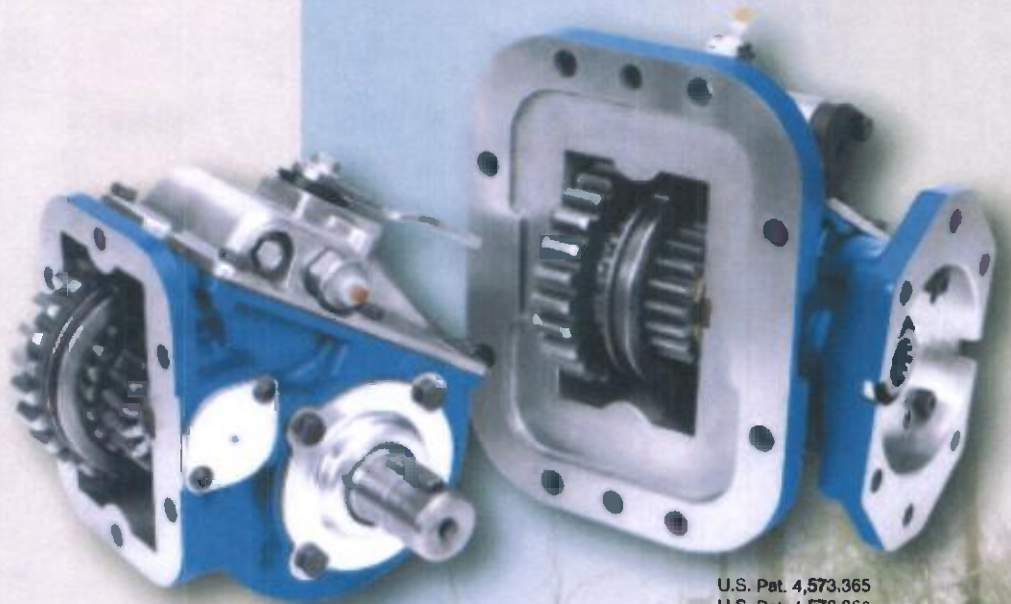

U.S. Pat. 4,573,365
U.S. Pat. 4,573,366



Muncie Power Products introduced the TG Series PTO in 1982. While many of its innovative features have been copied, no one has come close to offering a more complete, easy to use PTO system.

The TG Series PTO was built to be convenient, durable and reliable. Since its conception the TG Series has proven to be the workhorse of the Muncie line of PTOs.



Covers for shifting by air, electric/air, cable, electric/hydraulic, hydraulic, constant mesh, Lectra Shift or E-Hydra exclusive.

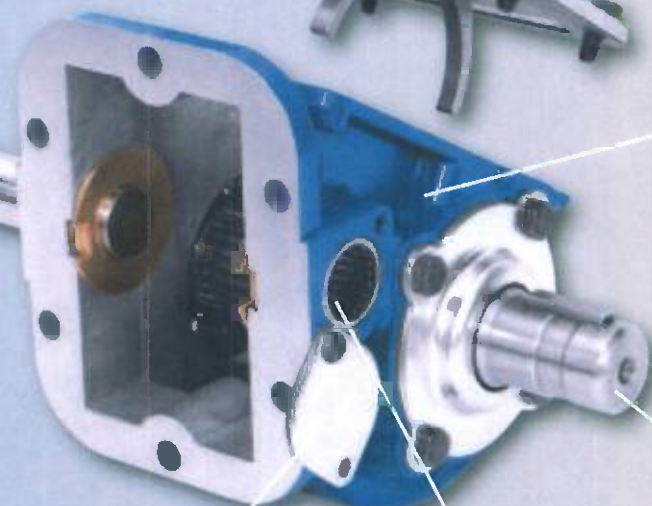

Compact housing in SAE six and eight bolt designs with small overall envelope size to simplify installation. Aluminum housing construction for lighter overall weight, greater sound diffusion and higher impact resistance than cast iron.



Nineteen output shaft options available including fifteen hydraulic direct mounts.



Removable end plates allow easy access for changing input gears.



Superior bearing and gear design profile for quieter operation and long life.

Easy to change speed ratio gear sets to cover capacities from 33 to 54 HP at 1,000 RPM and torques from 175 to 285 lb.-ft.



Muncie Power Products, Inc.

Muncie TG Series

POWER TAKE OFF SYSTEM

OVER 75
TRANSMISSION
GEAR PITCHES



10 SPEED
RATIOS



TO CHANGE
INPUT
GEARS,
simply remove
the end plates
and push out
the shaft with
simple finger
pressure.



Gears then easily slip out and drop back in place with no requirements for special tools.

19 OUTPUT
OPTIONS

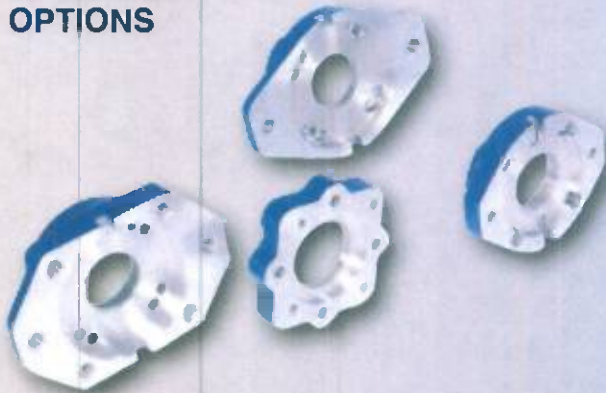

The TG Series is available with 15 multiple-position hydraulic direct mount flanges. Three are externally greaseable. All are designed to provide the best possible mounting orientation to avoid interference. This simplifies installation and eliminates driveline issues.

7 SHIFTING CHOICES



E-Hydra Shift



Air Shift



Cable Shift



Lectra Shift

U.S. Pat. 5,287,939

Available shifters include: E-Hydra, Air, Electric/Air, Electric/Hydraulic, Cable, Lectra Shift electronic solenoid and Constant Mesh.

Distributed By:

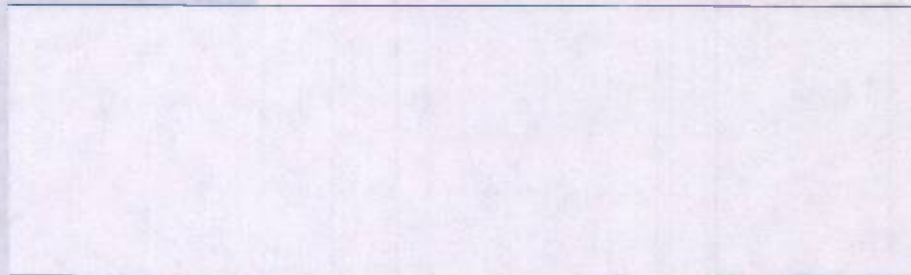

MP91-01 (Rev. 8-07) Printed in the U.S.A.
© Muncie Power Products, Inc. 2007

Muncie Power Products, Inc. Member of the Interpump Hydraulics Group
General Offices and Distribution Center • P.O. Box 548 • Muncie, IN 47308-0548
(765) 284-7721 • FAX (765) 284-6991 • E-mail info@munciepower.com
Web site <http://www.munciepower.com>

Drive Products. Exclusive Agents for Canada. ISO Certified by an Accredited Registrar



KEEP IN VEHICLE
READ OPERATING INSTRUCTIONS
INSIDE BEFORE OPERATING PTO

PTO INSTALLATION and OWNER'S MANUAL

FOR ALL 6-BOLT AND 8-BOLT MOUNT
SERIES OF MUNCIE PTOS

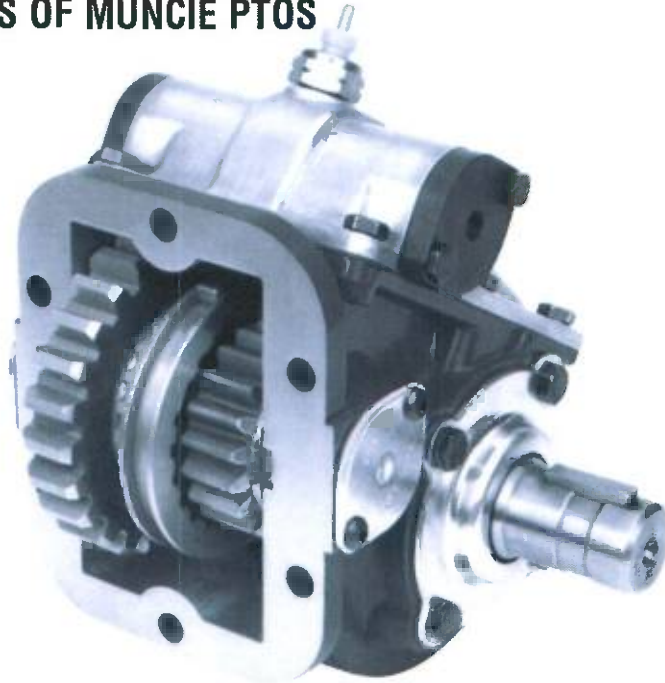

**Muncie®
Power
Products**















Muncie Power Products, Inc. Member of the Interpump Hydraulics Group
General Offices and Distribution Center • P.O. Box 548 • Muncie, IN 47308-0548 • (765) 284-7721
FAX (765) 284-6991 • E-mail info@munciepower.com • Web site <http://www.munciepower.com>
Drive Products, Exclusive Agents for Canada. ISO Certified by an Accredited Registrar

IN84-03 (Rev. 9-08) Printed in the U.S.A.

WARNING

READ MANUAL COMPLETELY INCLUDING THESE WARNINGS AND OPERATOR'S INSTRUCTIONS IN SECTION 3

-  READ AND UNDERSTAND ENTIRE MANUAL BEFORE INSTALLATION OR OPERATION OF PTO AND DRIVEN EQUIPMENT
 -  ALWAYS DISENGAGE THE PTO WHEN THE DRIVEN EQUIPMENT IS NOT IN OPERATION.
 -  DO NOT ATTEMPT TO INSTALL OR SERVICE ANY POWER TAKE-OFF WITH THE TRUCK ENGINE RUNNING. PUT THE IGNITION KEYS IN YOUR POCKET BEFORE GETTING UNDER THE TRUCK.
 -  DO NOT ALLOW TRUCK ENGINE TO BE STARTED WHILE WORKERS ARE UNDER THE TRUCK.
 -  IMMOBILIZE TRUCK WHEELS WITH SUITABLE CHOCKS BEFORE WORKING UNDER TRUCK.
 -  BE SURE TO BLOCK ANY RAISED BODY OR MECHANISM BEFORE WORKING ON OR UNDER THE EQUIPMENT.
 -  INSTALLED POWER TAKE-OFFS MUST NEVER BE SHIFTED IN OR OUT OF GEAR BY ANY MEANS EXCEPT BY THE CONTROLS IN THE CAB OF THE TRUCK.
 -  STAY CLEAR OF SPINNING DRIVESHAFTS TO AVOID BECOMING ENTANGLED AND INJURED.
- IT SHALL BE THE RESPONSIBILITY OF THE INSTALLER OF A MUNCIE POWER TAKE-OFF TO DECIDE WHETHER TO INSTALL GUARDS IN THE PTO AND/OR DRIVELINE AREA BECAUSE OF POTENTIAL EXPOSURE TO DANGER.
- THIS IS BECAUSE MOST MUNCIE PTOS ARE INSTALLED BY EQUIPMENT DISTRIBUTORS OR MANUFACTURERS AND THEREFORE, THE RESPONSIBILITY OF THE INSTALLATION IS BEYOND THE CONTROL OF MUNCIE POWER PRODUCTS.
-  OBTAIN PROPER TRAINING BEFORE OPERATING THIS MACHINERY
 -  DO NOT INSTALL OR OPERATE EQUIPMENT WHICH HAS NOT BEEN PROPERLY SPECIFIED FOR YOUR EQUIPMENT.
 -  ALLOW THE VEHICLE, PTO AND DRIVEN EQUIPMENT TO WARM UP WHEN OPERATING IN WEATHER WHERE TEMPERATURES ARE NEAR OR BELOW FREEZING 32 F (0 C).
 -  INSTALL SEPARATE CONTROLS FOR PTO AND DRIVEN EQUIPMENT
 -  ALWAYS INSTALL THE SAFETY LABELS PROVIDED AND PLACE THE OWNER'S MANUAL IN THE VEHICLE GLOVE COMPARTMENT.

The PTO is supplied with a packet containing warning labels. If you did not receive any, or if you need extra, you may order them, no charge, by phone, email, or mail. They are available through your nearest Muncie distributor or at the number and address below:

1-800-FOR-PTOS (367-7867)

**Muncie Power Products, Inc.
P.O. Box 548
Muncie, IN 47308-0548**

info@munciepower.com

 **This symbol warns of personal injury.**

© Muncie Power Products, Inc. 2008



PTO OWNER'S MANUAL

FOR ALL 6-BOLT AND 8-BOLT
MOUNT MUNCIE PTOS

TABLE OF CONTENTS

Section 1 PTO Installation

PTO Installation Instructions	1.1
Adapter Plates & Assemblies	1.10
Adapter Gear Installation	1.11
Filler Blocks	1.11

Section 2 Activation Kit Installation

Activation Kit Installation Instructions	2.1
Lever Shift Control	2.1
Cable Shift Instructions	2.2
Indicator Light Switch Continuity Check	2.7
PTO Equipped with Magnetic Pick-Up Sensor	2.7
TG Series Lectra Shift System	2.8
TG Series Wiring Diagram for E-Hydra-Shift	2.9
TG Series Standard Air Shift System	2.10
TG Series Electric/Air Shift System	2.10
82 Series Double Acting Air Shift System	2.11
RG, RL Series Standard Air Shift System	2.11
Automatic Transmission Diagrams	2.12
Clutch Shift and SH Series Electric/Air Shift System	2.18
Clutch Shift and SH Series Standard Air Shift System	2.20
Clutch Shift Electric/Hydraulic Shift System	2.21
Clutch Shift Instructions & Tests	2.22

Section 3 Owner's Manual

Power Take-Off Warranty	3.1
PTO Shifting Procedure & Precautions	3.2
Clutch Shift Operating Notes	3.4
PTO Maintenance	3.4
Indicator Light Check	3.5
PTO Torque & Horsepower Ratings	3.6
PTO Troubleshooting Guide	3.7

SECTION 1 PTO INSTALLATION

PTO INSTALLATION INSTRUCTIONS

Always wear safety glasses. Read entire manual before starting installation.

1. There is a packet with the PTO which contains 4 WARNING LABELS. Before adhering the labels, make sure the surfaces are free of dirt and grease. Place the labels supplied as follows:

There are two (2) labels which measure approximately 4" x 8" which are to be placed on the outside of the vehicle frame rail, making them easy to be seen by anyone who might go under the truck or near the PTO. One label is to be placed on each side of the vehicle.

Should the body installed on the chassis cover the frame rail, place the label on the body in a position easily visible by anyone who might go under the vehicle or near the PTO. **Do not paint over labels.**

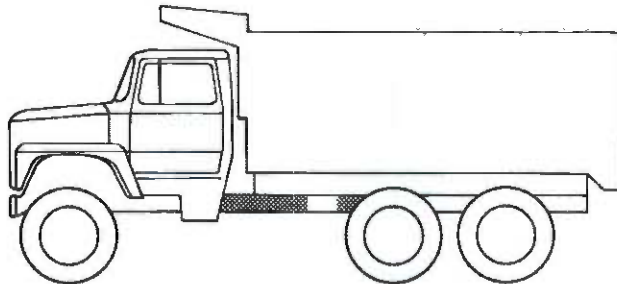
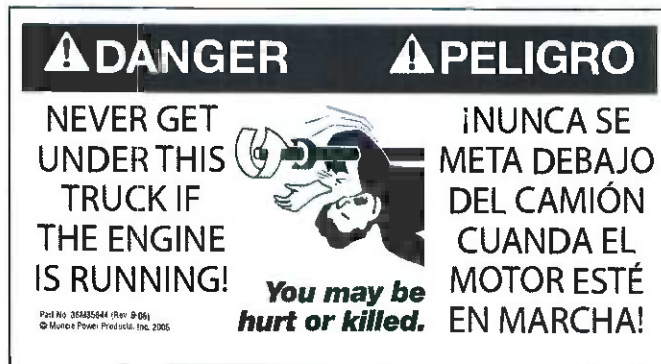
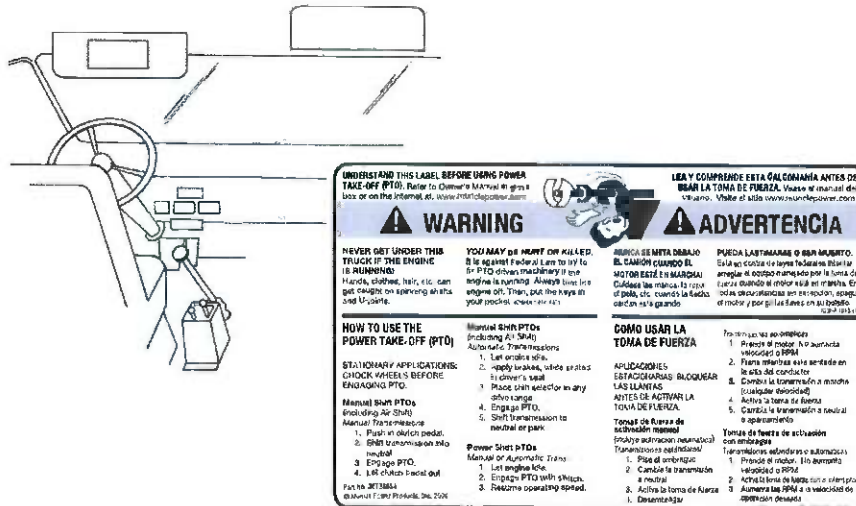

Figure 1.1

There are two (2) 4" X 8" labels supplied and one is to be placed on each side of the vehicle.

2. The 2" x 3" PTO Equipped Caution Label is to be placed within the cab of the vehicle and in easy view of the vehicle operator. It should be located near the PTO control, when the control is installed in the vehicle dash (See Figure 1.2). This label directs the operator to read the PTO operating instructions on the Visor Label. The Visor Label 4" x 6 1/2" is to be placed on the visor on the operator's side of the vehicle (See Figure 1.2). Do not mount this label on the same side of the visor as the air bag warning label if so equipped. Vehicles with hydraulic dump pumps are supplied with a Warning label to be mounted in clear view of the operator while seated in the driver's seat.



WARNING	ADVERTENCIA
THIS VEHICLE IS EQUIPPED WITH A POWER TAKE-OFF	ESTE VEHICULO ESTA EQUIPADO CON UNA TOMA DE FUERZA
READ AND UNDERSTAND OPERATOR'S MANUAL BEFORE USING THIS MACHINE.	IMPORTANTE, FAVOR DE LEER Y CONSULTAR EL MANUAL DE OPERACION ANTES DE OPERAR Y MANEJAR ESTA UNIDAD.
FAILURE TO FOLLOW OPERATING INSTRUCTIONS COULD RESULT IN DEATH OR SERIOUS INJURY.	EL NO SEGUIR LAS INSTRUCCIONES DE OPERACION PUEDE RESULTAR EN HERIDAS PERSONALES O EN LA MUERTE.
© Muncie Power Products, Inc. 2009	Part No. 302A9552 (Rev. 9-08)

WARNING	ADVERTENCIA
THIS VEHICLE IS EQUIPPED WITH A POWER TAKE-OFF AND HYDRAULIC DUMP PUMP	ESTE VEHICULO ESTA EQUIPADO CON UNA TOMA DE FUERZA Y BOMBA DE VOLTEO
FAILURE TO DISENGAGE THE PTO AND DUMP PUMP WHEN NOT REQUIRED CAN RESULT IN EQUIPMENT DAMAGE AND/OR PERSONAL INJURY.	EL NO DESACTIVAR TANTO LA TOMA DE FUERZA COMO LA BOMBA DE VOLTEO PUEDE RESULTAR EN DAÑO AL EQUIPO Y/O HERIDAS PERSONALES
© Muncie Power Products, Inc. 2009	Part No. 38140001

Figure 1.2

3. Manual Transmissions: While driving the truck into the work bay note if a delay is required between depressing the clutch and shifting the main transmission gear selection. If the gear does not come to a complete stop within a few seconds, the clutch linkage on the truck must be adjusted before installing the PTO. Run transmission in neutral. Determine sound of transmission before the PTO is installed. A transmission noise may be more noticeable after PTO is installed.

Stop engine.

4. For manual shift transmissions, drain transmission fluid. For Allison automatic transmissions, do **not** drain transmission fluid, but be prepared for a small amount of oil to escape from opening.

Remove cover plate. Place a shop towel in the opening to prevent dirt from getting in the transmission.

Examine cover plate. If there is a magnet attached to the inside, reinstall this cover on the other opening.

Clean mounting pad. Inspect bolt holes in aperture for thread sealant used on OEM bolts. Clean these internal threads with wire brush to clear the material. **Remove shop towel.**

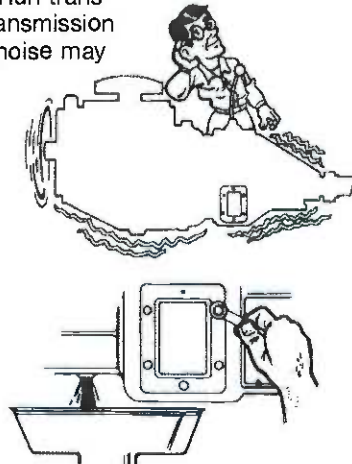

5. Check transmission for proper PTO driver gear and location. Do not place anything in or near PTO opening while the engine is running.

Stop engine and remove keys before proceeding to next operation.

Check PTO driver gear for condition. A nick or blemish may cause excessive noise when PTO is mounted.

6. Rock transmission gears by hand to get feel for gear backlash manufactured into transmission gear set.

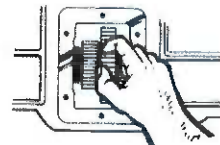

7. Open the PTO carton and find the mounting kit (studs and cap screws) enclosed with your PTO. Visual inspection of the PTO will indicate which mounting holes in the PTO will not accept cap screws. Install the enclosed studs in the transmission housing holes that correspond to those PTO holes which will not accept cap screws. Additional instructions may be found on the supplement sheet enclosed with PTO. Install adapter gear at this point if it is required. (Go to page 1.10 if adapter gear is used.) PTOs with mounting option 6F have two dowel pins which need to be placed in the mounting pad before mounting PTO.

8. Install the studs until the barrel of the stud is even with the transmission pad. This typically requires a torque limit of 30-35 lbs.-ft. (6 bolt pad) or 45-50 lbs.-ft. (8 bolt pad). If more torque is required to install the stud to the barrel or to the depth shown in the below table then remove the lock patch from the stud and the transmission mounting holes and use a liquid loctite in its place (#242).

The studs should be engaged to the minimum depth as shown below:

Stud Dia.	No. Threads	Approx. Depth
3/8"	7 - 8	1/2"
7/16"	8 - 9	5/8"
10mm	9 - 10	1/2"

9. Remove the shifter cover or the inspection cover plate from the PTO by removing the hex head cap screws on the cover plate. With PTOs which do **NOT** have an inspection cover plate, hold the output shaft and rock input gear to get the feel of backlash built into the PTO. This feel will be helpful when fitting PTO to transmission. (Step 12)

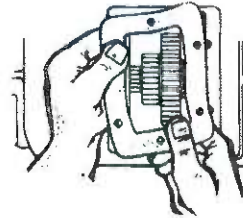

10. Place mounting gasket/shim from your kit over the studs already installed on the transmission. A thin coating of approved transmission oil is recommended on gasket/shims to help seal and to hold them in place during installation. The PTOs for the Eaton Lightning Transmission are designed to be mounted without gasket/shims and require the use of a gasket eliminator which is supplied with the PTO.

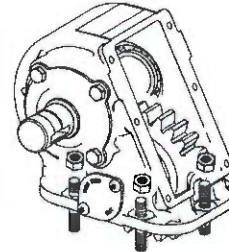

Do **not** use a permanent sealant on gasket/shims because you may need to change them later. Use approved transmission oil only!

11. Position the PTO on the studs and start the nuts provided onto the studs. Do Not Tighten Yet. Check for gaps between the PTO and transmission and make sure gear teeth are properly meshed and then tighten the top and bottom nuts or cap screws. On some transmission models the TG Series PTO may encounter interference with the idler shaft cap. Special clearance caps may be used and are listed in the application catalog where known interference exists.
12. Check the backlash on the input gear (gear that meshes with transmission gear) by feeling through the inspection hole or shift cover opening previously uncovered in step 9. The amount of rotational movement of the PTO gear should be only .006" to .012". As a reference, the thin gasket/shim in your installation kit is .010" thick. The thin gasket/shim (.010" thick) will change the backlash approx. .006". The amount of movement of the input gear would only be about the same distance as this gasket/shim thickness. At least one gasket/shim **must** be used. Do not stack more than (4) gasket/shims together. On Allison transmissions (Series AT-500, MT-600, HT-700, 1000, 2000, 2400 only) the single .030" gasket/shim (13M13541) should be required and is supplied with PTO. The CS6B/SH6B-A6907 series and TG6B-A69** Series uses the 23M60270 spacer and requires gasket/shims and backlash checks as described below.

Special Instructions for Allison 1000 & 2000 Series Transmission Installations.

Noise can occasionally be emitted from the PTO when installed on the Allison 1000/2000 Series transmissions that may be objectionable to the operator. The following instructions assist in reducing this noise.

Noise emitting when the unit is disengaged and the reduced or extinguished when unit is engaged is common for this installation and is not a signal of advanced failure. Muncie Power Products does not consider this noise to be a warrantable condition.

TG SERIES

When installing the TG series note that the PTO is provided with several gaskets and a steel spacer 23M60270.

Install the PTO using two .020 thick gaskets provided, using one on each side of the spacer.

Check the backlash. Backlash measurement should be in the range .010 to .024 .

If the PTO is noisy in the off mode, but quiet when engaged, then remove PTO and re-install with all of the gaskets provided.

CS6 SERIES

CS6B-A68 03 thru 05 ratios: When installing the PTO use one of the two 13M13541 gaskets.

If PTO is noisy in the off mode and quiet when engaged then, remove PTO and re-install using both 13M13541 gaskets provided.

CS6B-A69 07 ratio: Install the PTO using two .020 thick gaskets provided, using one on each side of the 23M60270 spacer provided with PTO.

Check the backlash. Backlash measurement should be in the range .010 to .024 .

If the PTO is noisy in the off mode, but quiet when engaged, then remove PTO and re-install with all of the gaskets provided.

GM6B/ GA6B SERIES

Install PTO using both 13M13541 gaskets provided. See IN03-01

Notice: For some Warner W80 applications, a maximum of one thin gasket/shim (.010") is required. If backlash is too excessive, remove the gasket/shim and use Loctite Gasket Eliminator sealant Muncie #13M51717. A .20 ounce tube has been supplied with the PTO for these applications.

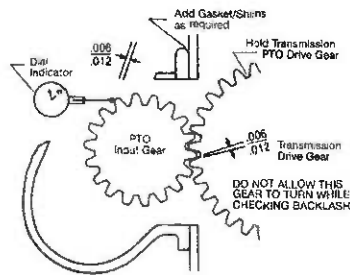

Use of a dial indicator can greatly improve the quality of the installation. Mount the indicator so that the plunger aligns with a tooth on the PTO input gear. Hold the transmission gear with screw driver or bar and rock the PTO gear back and forth with your hand. The

total movement on the dial indicator should be between .006" - .012". Check the backlash at different points around drive gear to find the worst condition. NOTE: Never use silicone type sealant on PTO/transmission mounting surface as proper backlash cannot be attained.

- 13.** Torque all the mounting cap screws or nuts to 40-45 lb-ft (6-bolt pad) or 50-55 lb-ft (8-bolt pad) unless noted in a separate stud kit instruction. Failure to properly tighten capscrews or nuts can lead to leaks. PTO and/or transmission damage can occur. **Improper installation, tightening, or leaks are not the responsibility of Muncie Power Products, Inc.**

Recheck the backlash.

The PTO gear should not move more than .012 or less than .006 when all mounting nuts or bolts have been torqued.

- 14.** Replace shifter cover or inspection cover plate and gasket on the PTO. **Shifter cover gasket can be found in the instruction envelope. It is required to use a gasket under the shift cover.** Torque cap screws to 14-18 lb.-ft. Double check to make sure the shifter fork is in the groove on gear or shift collar before tightening cap screws. On the TG Series shifter cover, the installation and torquing of the capscrew should be in an "X" pattern starting with the center capscrews and crossing the cover during installation. Torque the capscrews using the same pattern.

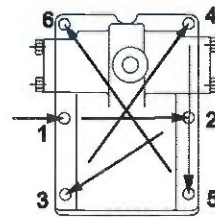

- 15.** Start the truck engine (with transmission and PTO in neutral) for a few seconds and listen for unnatural noises. Stay clear of rotating components. A whine noise indicates the PTO is mounted too tight. Stop engine and add a gasket/shim. A clatter noise indicates a loose mount. Stop engine and remove a gasket/shim. Add sealant (Loctite gasket eliminator) if no gasket is used.

A PTO will not always make these noises.

Do Not adjust backlash by noise alone, always visually check backlash.

Sometimes filling the transmission with lube is the only way to reduce the noise.

A tight mounted PTO will cause under cutting of gears and result in premature PTO failure, including gear or housing breakage.

If OK, repeat test with PTO engaged.

Caution: Keep PTO/transmission running time as short as possible until transmission is refilled with lube. Do not drive the truck without transmission lube.

- 16.** Refill transmission with manufacturer s approved fluid and run engine for 5 to 10 minutes to check for leaks. **Stay clear of rotating components. Stop Engine! Inspect the cap screws, nuts, and studs to make sure they are properly tightened. After completing installation, installers need to check for leaks and proper mounting torque of PTO fasteners. Refer to Step 21.**

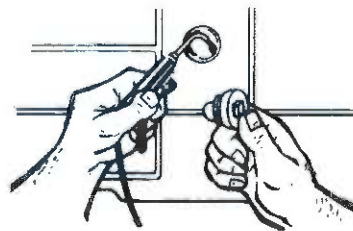

- 17.** Install the appropriate shifter kit components, including the supplied PTO shift indicator light. Refer to page 2.1 for lever shift, page 2.2 thru 2.7 for cable shift, page 2.8 for the Lectra Shift TG series PTO, pages 2.9 thru 2.10 for Air Shift PTOs, and pages 2.11 thru 2.20 for Clutch Shift PTOs.

On air system only, you will not receive any air through the pressure protection valve to the PTO system until your main tank pressure exceeds 65 PSI.

- 18.** If your system utilizes a driveline between the PTO and another device and if you have noise in your system that was not there before, the angularity or phasing of your driveline may be the cause. Check driveline angularity and reduce total angularity per recommendation on chart and be sure the PTO shaft is parallel within 1.5 to the pump shaft (or driven unit). Drivelines must be in phase, that is, the yoke ears on the PTO and pump shafts must be in alignment, as illustrated below. PTO with Direct Couple Hydraulic Pump Installation

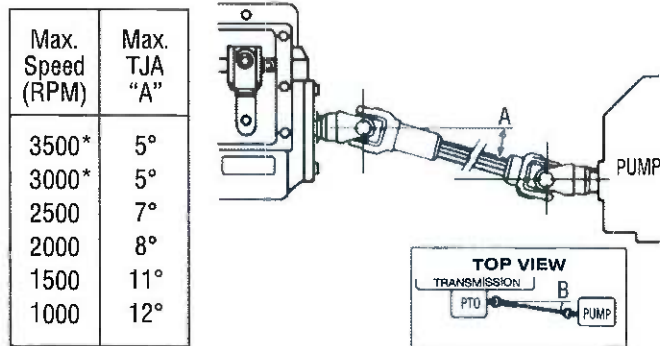

* For speeds over 2500 RPM contact Muncie for Approval.

For installations with angles in the top and side views use this formula to compute the true joint angle (TJA):

$$TJA = \sqrt{A^2 + B^2}$$

FOR CABLE OR LEVER SHIFT INSTALLATIONS ONLY.

Before bolting the pump to the PTO, place non-seizing compound or grease on the PTO shaft and pump shaft.

All Muncie direct mount PTOs are supplied with the appropriate grease. Reusing an existing pump will require inspection of the pump splines. Clean any old grease from pump prior to installation.

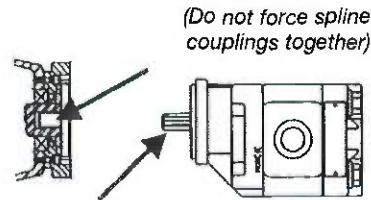

When mounting hydraulic pumps weighing over 40 lbs.*, exceeding 12" in length, or for tandem or multiple section pumps, a rigid support bracket must be installed. It should be attached to the rear of the pump and to the transmission to support the pump and to inhibit movement in all directions.

**Weight includes fittings, oil, and unsupported hose sections.*

This requirement does not take into account the system duty cycles, vehicle vibrations, application, terrain, and other external influences. We recommend that direct mounted components of any size or weight be supported when these conditions are extreme or unknown.

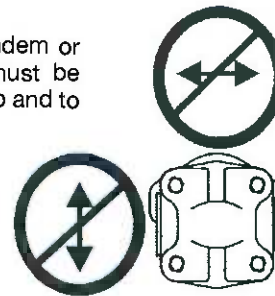

This recommendation is based upon our experiences to date. Bracket design illustrations and pump recommendations is to be used as a GUIDELINE ONLY. Bracket design shown is representative and is not to be duplicated for all applications. Any failure as a result of damage caused by unsupported weight attached to the PTO will affect any warranty considerations.

The drawings below are examples of how the bracket may be constructed. A bracket attached to two or more transmission bolts and two pump bolts is required. The bracket design should assure that there is no stress or force exerted on the pump or PTO shaft.

If the vertical supports are greater than 20 degrees off of perpendicular with the transmission main shaft then a reinforced Z bracket must be used. Reinforce horizontal members to prohibit flexing at bend or weld. Attach the bracket at the pump bolt closest to the center of gravity of the pump.

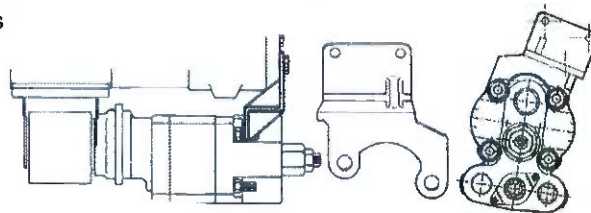

Most Muncie direct mount flanges offer multiple mounting bolt holes which allow the flange to be rotated to multiple locations on the PTO for improved port location or clearance. Be sure to torque the cap screw to 25 ft.lb., and it is advisable to use a thread locker to secure the cap screws (Loctite 241 or NyLoc or equivalent).

- 19.** Greaseable hydraulic output shaft option. PTOs with the **G** special feature option have a grease zerk fitting behind a cover on the closed end cap of the output shaft. Grease needs to be added after the pump has been installed using a grease gun. Use a high temperature, high pressure, EP type grease.



20. FOR CABLE OR LEVER SHIFT INSTALLATIONS ONLY.

For **CLUTCH SHIFT** installations, skip to pages 2.12 - 2.21.

Using the metal plate as a template, drill holes in dash near cable knob and attach indicator light as shown at right.

Battery connection should be an ACC tap on fuse panel.

Install light in a position which is visible to the operator when operating the PTO and the vehicle.

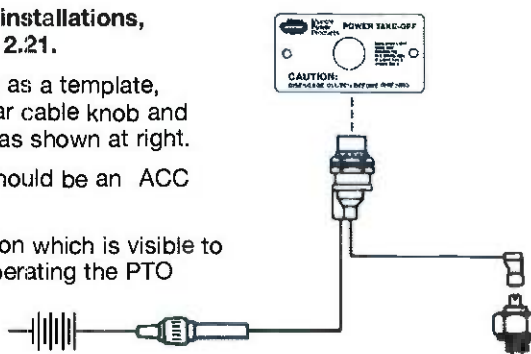

The indicator light is to be connected so that when the PTO is engaged the light is ON and the light is OFF when the PTO is disengaged.

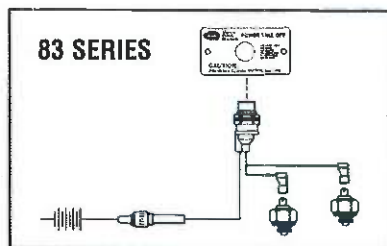

Do not install any other electrical devices to Muncie indicator switches, or to pressure switches. See page 2.12 for wiring indicator switch to the Eaton Fuller CEEMAT transmissions.

- 21.** Complete installation by placing warning labels as indicated on borders of the decals. Placement examples are illustrated on pages 1.1 and 1.2. Turn to Section 3 of Owner's Manual.

After complete installation, installers needs to check for leaks and proper mounting-torque of fasteners. Operate the equipment for an appropriate amount of time established for proper operation or per the equipment manufacturer's recommendation. After shutting down equipment and engine, check for leaks. Allow unit to sit for 60 minutes, then check again for any leaks. Fix all found leaks per manufacturer's recommendation.

Muncie Power Products, Inc. is not responsible for any damage resulting from installation, mounting torque or maintenance of the PTO.

22. Complete installation by placing warning labels as indicated on borders of the decals. Placement examples are illustrated on pages 1.1 and 1.2. Turn to Section 3 of Owner's Manual.

ADAPTER PLATES & ASSEMBLIES

See Muncie Quick Reference Catalog for specifications.

ADAPTER PLATES are used to convert an SAE 8-bolt aperture to an SAE 6-bolt aperture.

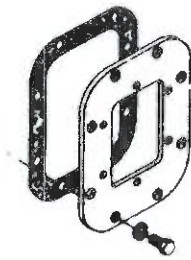

Adapter Plate

Adapter plates mount to the transmission pad with included gaskets and capscrews. The 1/4" plate has a raised pad to provide proper thread engagement.

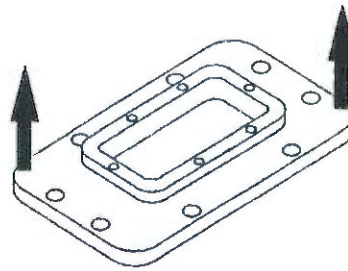

Mount Towards Transmission

This raised pad is to be mounted toward the transmission opening and the PTO is mounted to the flush side of the plate.

ADAPTER GEAR ASSEMBLIES are normally used to reverse the rotation of the PTO output shaft. They are also commonly specified to clear mounting obstructions. Standard adapters will move the PTO outward from the transmission approximately three inches. Adapters often reduce the application horsepower ratings and service life. Contact Muncie for specific information regarding your application.



Solid Body - Single Gear



Angular Cluster Gear



Flanged Body - Single Gear



Vertical Offset Gear

ADAPTER GEAR INSTALLATION

Before installing the adapter gear be sure to read all of the instructions in this booklet for installing a PTO. Follow all the safety instructions listed when installing the adapter as you would for installing the PTO. Make sure that the engine is turned off and wheels are immobilized before starting any installation.

1. Follow steps 1 through 7 on pages 1.1 through 1.3 of this manual.
2. Before attempting to mount adapter to transmission, bench mount the adapter to the PTO using studs or capscrews in at least the top and bottom stud holes.
3. Using gaskets and spacers (if required) adjust the backlash between the adapter and the PTO so that it is between .006" to .012". Some adapters are supplied with gasket eliminator instead of gaskets. Apply a bead evenly around the surface of the mounting pad.
4. After spacing between PTO and adapter is adjusted remove the adapter from the PTO and carefully save the Gasket Pack you have just created. Mount the adapter to the transmission using at least the top and bottom stud holes. Adjust the backlash of the adapter to the transmission so that it is .006" to .012" inches. Refer to steps 8 through 12 on pages 1.3 and 1.4 for additional instructions on backlash.
5. Using the Gasket Packs created from earlier steps, mount the PTO to the adapter using all six studs stud holes and return to the instructions on page 1.3, step 8 and continue the installation until completed.

FILLER BLOCKS/SPACERS

FILLER BLOCKS are often required in transmission applications where it is necessary to use a spacer to adapt the PTO to a particular transmission. Two filler blocks may be used in combination with one or more gaskets between the filler block surfaces. A minimum of one (1) gasket is required between each surface. Refer to notice supplied with the filler block for more information.

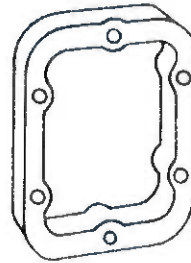

SECTION 2

ACTIVATION KIT INSTALLATION

ALL INSTALLERS *MUST* READ THE FOLLOWING

ACTIVATION KIT INSTALLATION INSTRUCTIONS

IMPORTANT: *Disconnect vehicle battery and bleed air tanks with engine stopped prior to installing electrical or air activation kits.*

- A.** Vehicle manufacturers may have specific locations for the accessing of electrical power, activating hydraulics, and air. The body builder manual or company representative for the vehicle chassis should be contacted prior to installing electrical or pneumatic systems.
- B.** Route wires, hydraulic activation lines, and air lines away from rotating and high temperature components. Use appropriate looms and bulkhead pass-thrus wherever possible to avoid rubbing through insulation or tubing and causing an electrical short or air leak.
- C.** Follow all Federal Motor Vehicle Safety Standards (FMVSS) for your vehicle.
- D.** Where electrical grounds are indicated, be sure that they are good grounds, with straight paths to the vehicle battery ground. (Many vehicle cabs are insulated from the vehicle frame and a weak ground is a very common cause for malfunctions). Check with the vehicle manufacturers for the proper ground location or connect directly to battery.
- E.** When installing hydraulic components, be certain to follow common installation and testing procedures. If you are not familiar with acceptable installation procedures request instructions and guidance from the hydraulic equipment supplier.
- F.** Note that when installing the PTO air systems the installation of a pressure protection valve is required at the air tank. This valve is not a pressure regulator, it is a pressure check valve which does not allow air to the PTO system until the system air pressure exceeds approximately 65 PSI.
- G.** Cold weather start conditions require that the transmission be started and warmed prior to engaging and using equipment. Hydraulic pumps should be run at idle and under no load conditions to allow oil to warm before activating hydraulic system.

LEVER SHIFT CONTROL

Install indicator light as described on page 1.8, step 19.

Muncie PTOs with lever shift options (available on *RG, RL, 82, 83 Series only) require the customer to provide the linkage and hook-up to the PTO. The PTO is provided with an eye bolt for this purpose.

The PTO is designed with detent ball and spring to locate the engage and disengage positions, but it is *not* designed to lock into these positions. A neutral detent to prevent unintentional or accidental engagement *must* be installed on the external shift linkage. This detent must be included by the installer of the linkage.

Tighten after shifting adjustments have been made.

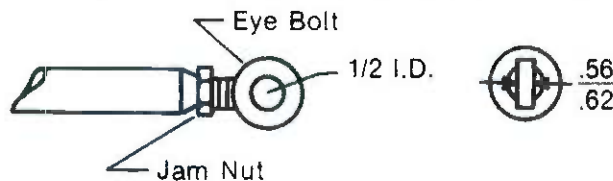

CABLE SHIFT INSTRUCTIONS

TG SERIES PTO

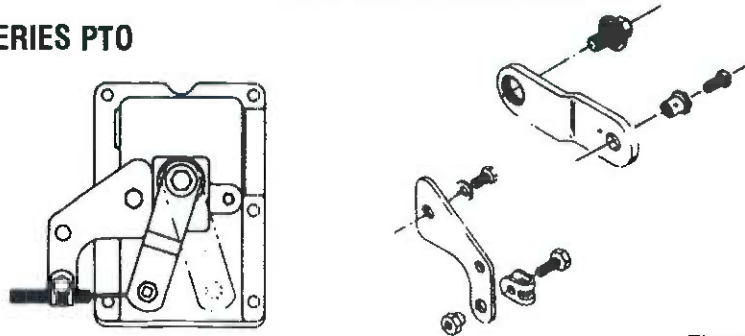

Figure 2.1

SG SERIES PTO

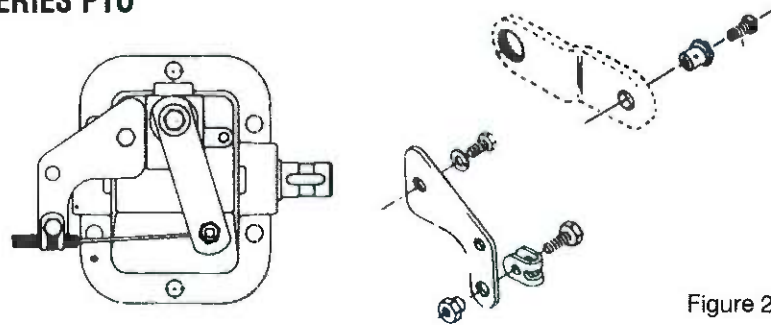

Figure 2.2

RG SERIES PTO

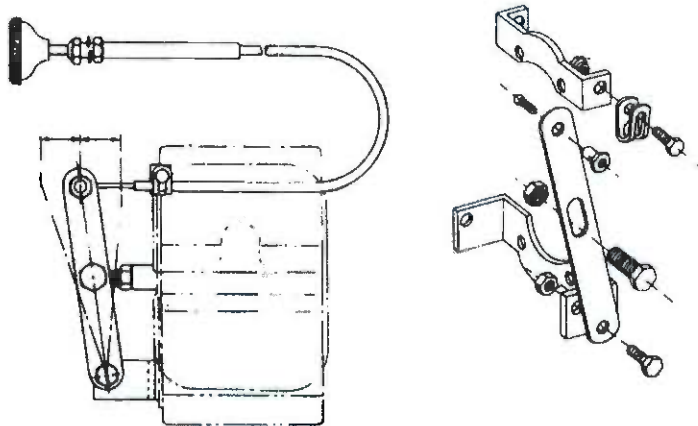
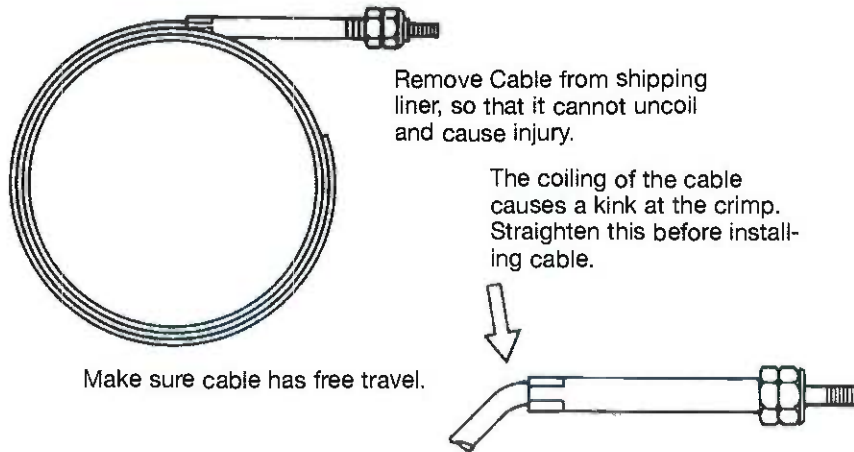

Figure 2.3

WARNING: All cable shift controlled PTOs are designed to be shifted only by wire cable. The unauthorized attachment of lever control linkage to a cable control mechanism may cause damage to shifting components and, subsequently, the transmission. The unauthorized attachment of the lever control linkage to a cable control mechanism may cause the PTO to engage unintentionally due to linkage bounce or flail.

CABLE SHIFT INSTALLATION INSTRUCTIONS

Be sure vehicle is not running when installing or adjusting cable control. After removing the cable from shipping liner (being very careful to hold cable so that it cannot uncoil and cause injury) straighten cable at crimp that has resulted from being coiled. Make sure cable has free travel before installing.



1. Find a suitable location for the control cable and the indicator light. The cable control should be installed so that the operator has easy access to push in and pull out the control without obstruction or interference by other controls or components in the cab.
2. Drill a 1/2" hole in dash or control bracket (not provided).
3. Install the control head through the hole and attach with the lock washer and nuts provided.
4. Knob can be screwed into place, using the jam nut to secure.

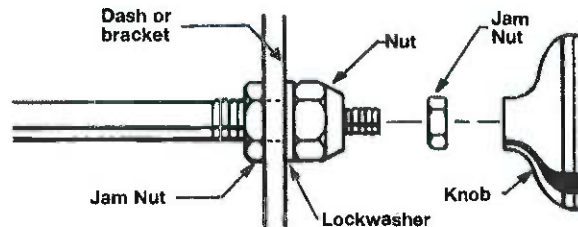
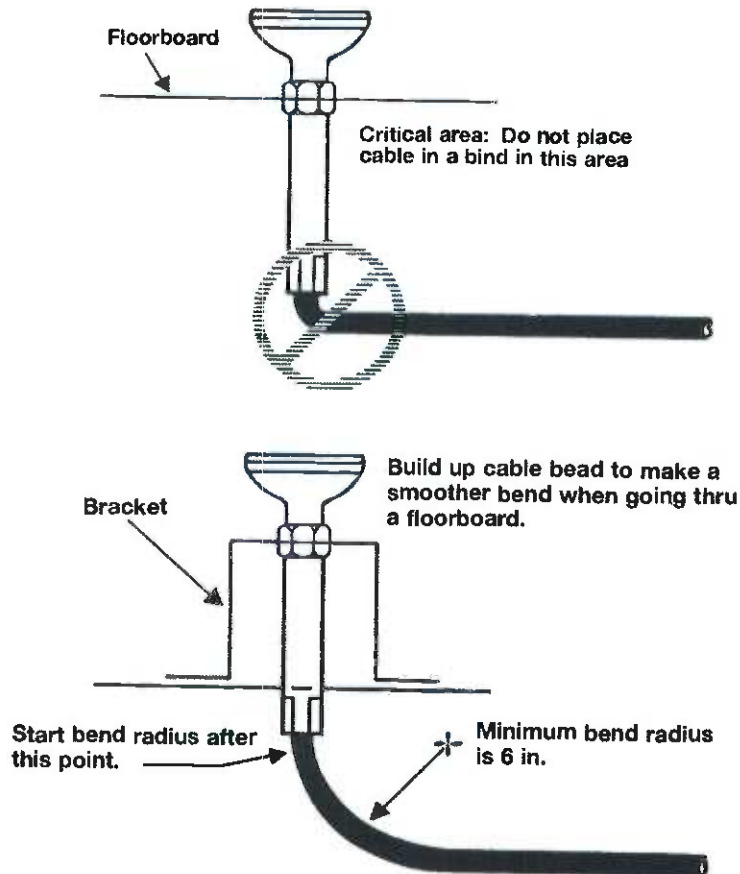

Figure 2.4

5. Route the length of cable through the floorboard or firewall and to the PTO. The cable needs to be routed clear of manifold, exhaust systems, and rotating and moving components. When routing the control cable avoid kinking the cable and do not bend to radius of less than 6"



6. The lever on the PTO shifter assembly is designed so that it can be moved to allow the cable approach to be from the front or the back of the PTO. This should be determined by the routing method causing the least amount of bends and the shortest cable length.
7. The lever, also must be positioned so that when you pull on the control knob that the PTO engages. (The RG Series should have a detent position for neutral, instead of pushing all the way in for neutral.)

8. To adjust the lever, mark the position of the lever where it's engaged when the cable would pull the lever. **Remove the shift cover from the PTO.** Remove the locking capscrew from the control lever. Lift the lever from the serrated post. Line up the lever with your mark. Line up the serrated hole and post making sure that the poppet and the shift plate are in their respective positions. Replace the locking capscrew and torque to 18 ft.lb. Reinstall shift cover assembly. Double check the installation by referring back to step 7 on the previous page 2.4.

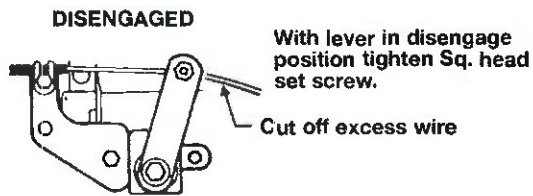
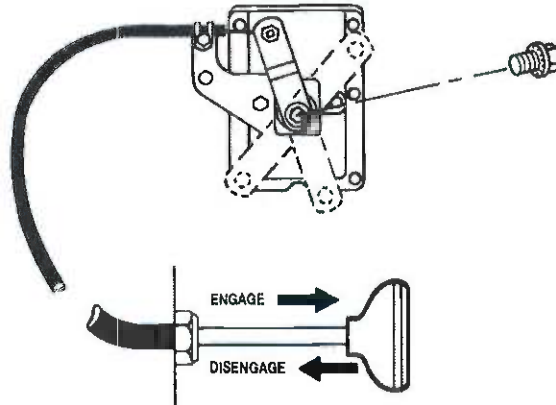

Move lever to its fully disengaged position and the cable knob to its fully disengaged position.

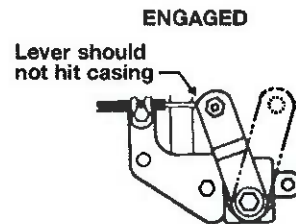

9. Referring to Figs. 2.1, 2.2, 2.3 on page 2.2, install the appropriate brackets, clamps, and hardware.

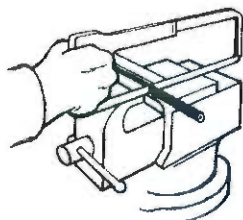

STANDARD PTO CABLE

If the cable is too long, remove the inner wire and cut casing (only) to length with a hacksaw or large side cutters.

If longer cables are required - they are available from your nearest Muncie Independent Master Warehouse.

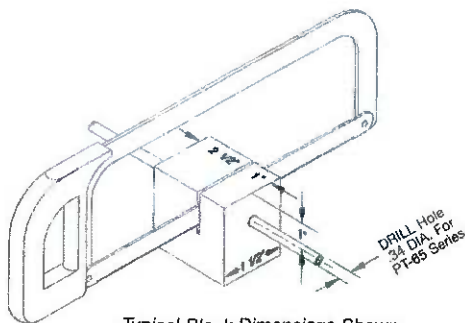

DELUXE (PT-65) PTO CABLE

Abrasive power cutting equipment is recommended for shortening this type of control cable. **Do not use a bolt cutter or similar tool.** Described here is a hand method for cutting cables where abrasive power cutting equipment is not available.

Make a holding tool by using a hardwood block of any convenient length as shown in the diagram. The hole should be of a size just large enough for the conduit to easily slip through.

The hacksaw should have a fine tooth blade (no less than 32 teeth per inch). Remove the inner wire before cutting conduit by pulling the control knob end from the control head. Remove the installed cable end by unscrewing it from the cable conduit and saving it for reinstallation.

10. It is recommended that the control cable casing be securely anchored, with cable clamps, approximately every 30", to the frame and/or cab to prevent movement during shifting. Cable mounting clamps can be purchased from your nearest Muncie Independent Master Warehouse. (part no. MT306-4)
11. Install the indicator light and warning labels by referring to steps 19 & 20 on page 1.9 of this instruction booklet. The indicator light is to be ON when the PTO is engaged and OFF when the PTO is disengaged.

Do not install other electrical devices to the Muncie indicator light switch.

Install cable so that you pull to engage and fully pushed in to disengage.

The PTO indicator light must be installed so that it is visible to the operator of the vehicle while seated in the driver's seat. Additional indicator lights may need to be purchased to comply with this requirement.

INDICATOR LIGHT SWITCH CONTINUITY CHECK

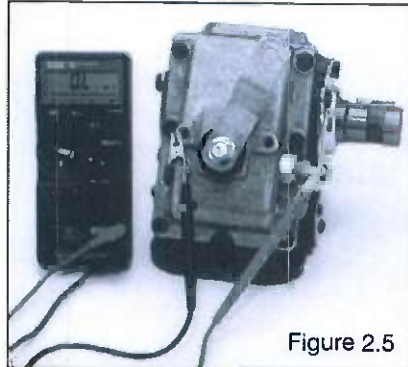

Figure 2.5



Figure 2.6

Performing a continuity check on the indicator switch will verify that the indicator switch is functioning and that the PTO is properly assembled.

1. Using a multimeter, connect one lead to the spade terminal on the indicator switch mounted to the PTO.
2. Connect the other lead to a bare metal portion of the PTO or shifter (Figure 2.5).
3. If the PTO is mounted on a vehicle, be sure that the engine is stopped, and the vehicle is safely immobilized to prevent any movement.
4. Engage the PTO. The meter will show continuity (Figure 2.6).
5. Shift PTO to the disengage position. The meter should return to normal (Figure 2.5).

This continuity check may be performed on any Muncie PTO. Only the air shifted models will require an air source to engage the PTO.

PTO EQUIPPED WITH MAGNETIC PICK-UP SENSOR

1. Mount the shift cover to the PTO (as required).
2. Align the internal gear tooth so that tip is centered in the pick-up opening.
3. Install the jam nut with the seal in the nut facing the PTO and back it down the pick up close to the wire end. Place washer then the o ring on the pick up so that the o ring will be against the PTO cover. Screw in the pick-up until the tip gently touches the top of the gear tooth.
4. Turn the pick-up backwards 2 turns. Rotate gear to make sure it clears.
5. Hold pick-up and tighten jam nut to hold in place.
6. Re-Check gear for rotation.

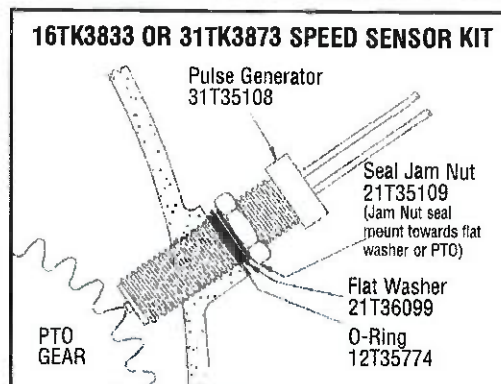

TG SERIES LECTRA SHIFT SYSTEM

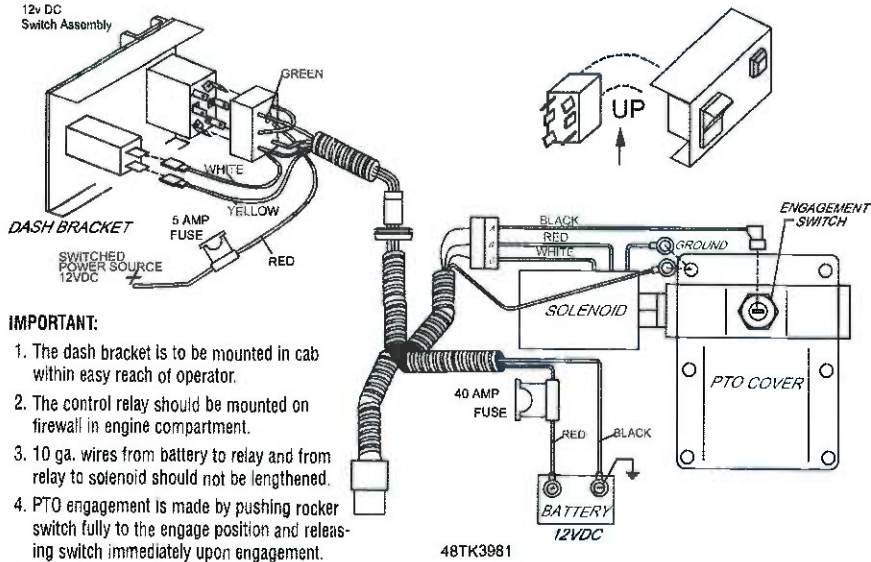

IMPORTANT:

1. The dash bracket is to be mounted in cab within easy reach of operator.
2. The control relay should be mounted on firewall in engine compartment.
3. 10 ga. wires from battery to relay and from relay to solenoid should not be lengthened.
4. PTO engagement is made by pushing rocker switch fully to the engage position and releasing switch immediately upon engagement.
5. Excessive repeated shifting of PTO can overheat solenoid and prevent engagement until allowed to cool down.
6. Drill .625 dia. hole in firewall near where control relay is mounted. Install black plastic grommet (P/N 37T35674) in hole and run the four wire connector through the grommet and plug into cab harness portion of harness. Plug the rocker switch receptacle onto the switch so that the green wire is up (matching the position of the green light on the rocker switch.)

SWITCH AND LIGHT INSTALLATION

1. Remove protective film from faceplate.
2. Lay faceplate on switch bracket and push switch into faceplate and bracket so that the green lens on the rocker is up.
3. Insert the indicator by aligning the flat with the hole in the faceplate and bracket, then push the light into place.

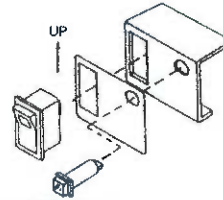

LECTRA SHIFT INSTALLATION WITH EATON FULLER CEEMAT

48MK1434-14 (1 or 4 Assembly) • 48MK1434-23 (2 or 3 Assembly)

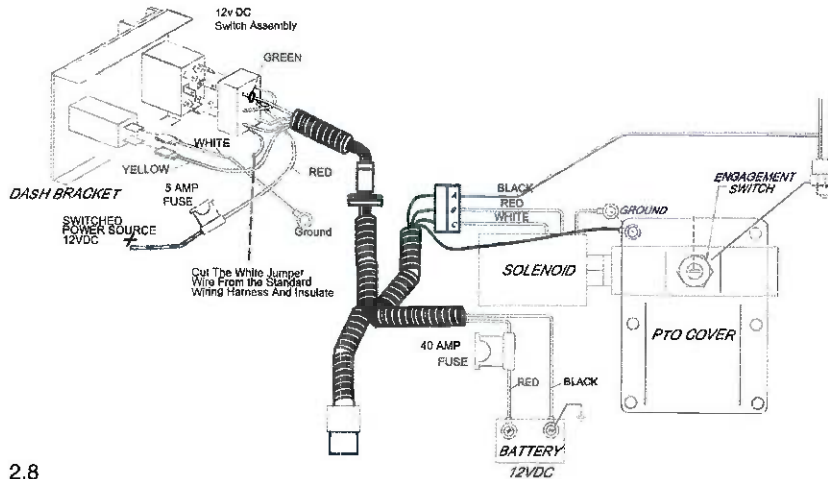

WIRING DIAGRAM FOR E-HYDRA-SHIFT TG SERIES

Activation Kit: 48TK4686

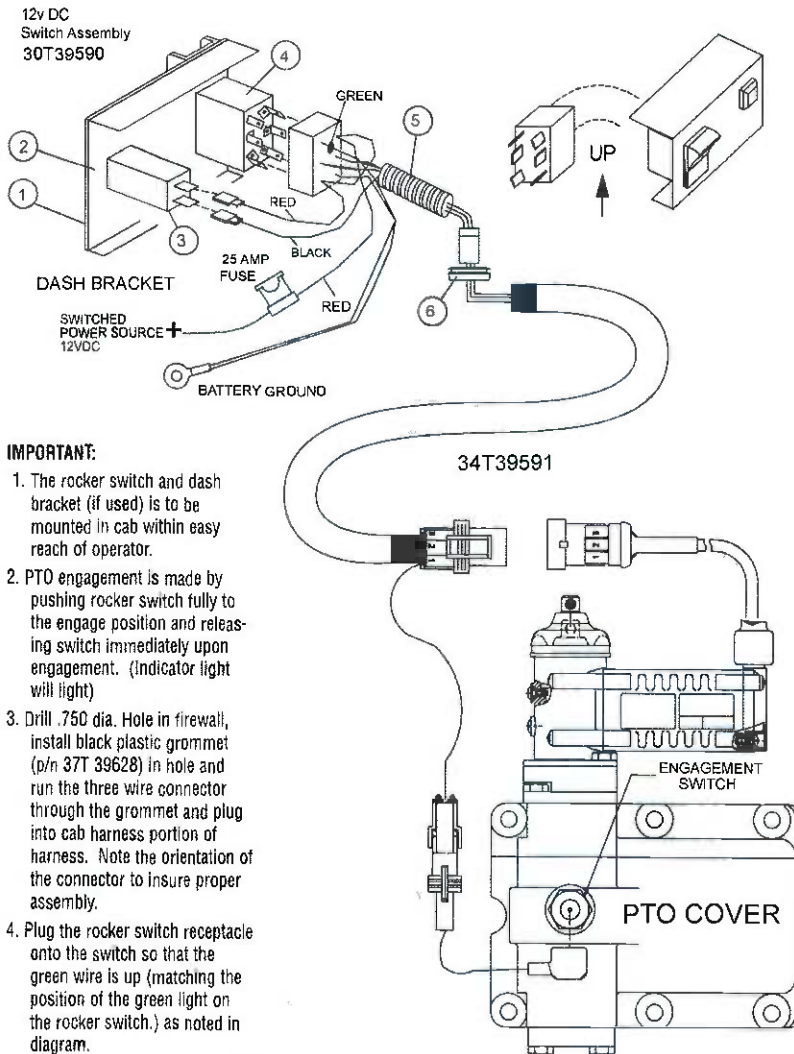

IMPORTANT:

1. The rocker switch and dash bracket (if used) is to be mounted in cab within easy reach of operator.
2. PTO engagement is made by pushing rocker switch fully to the engage position and releasing switch immediately upon engagement. (Indicator light will light)
3. Drill .750 dia. Hole in firewall, install black plastic grommet (p/n 37T 39628) in hole and run the three wire connector through the grommet and plug into cab harness portion of harness. Note the orientation of the connector to insure proper assembly.
4. Plug the rocker switch receptacle onto the switch so that the green wire is up (matching the position of the green light on the rocker switch.) as noted in diagram.

E-HYDRA SHIFTER

KITS

16TK5024 Standard (1 or 4 Assembly)

16TK5025 Standard (2 or 4 Assembly)

16TK5026 Allison 1000/2000 (1 or 4 Assembly)

16TK5027 Allison 1000/2000 (2 or 3 Assembly)

TG SERIES STANDARD AIR SHIFT SYSTEM

48M61250-A (12V Light)
48M62450-A (24V Light)

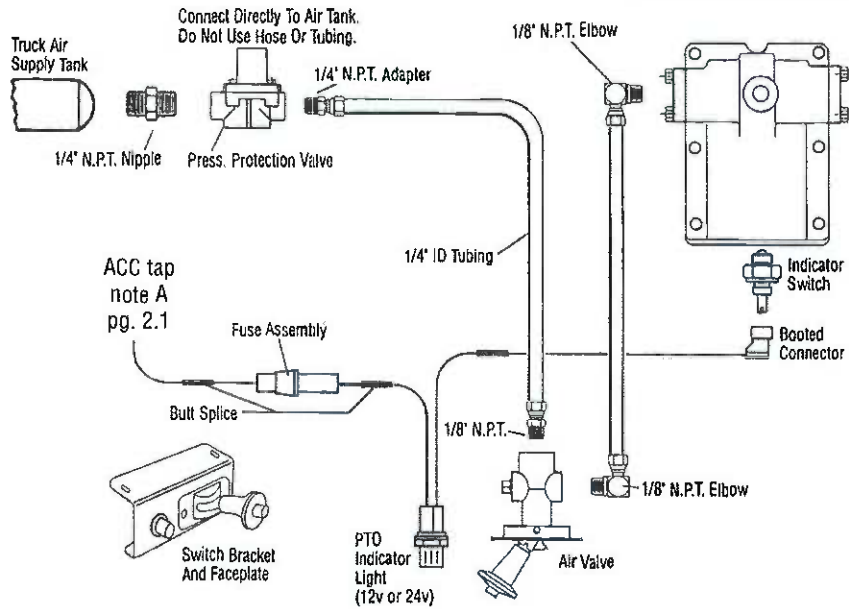

TG SERIES ELECTRIC/AIR SHIFT SYSTEM

48M61200-A (12V Solenoid & Switch)
48M62400-A (24V Solenoid & Switch)

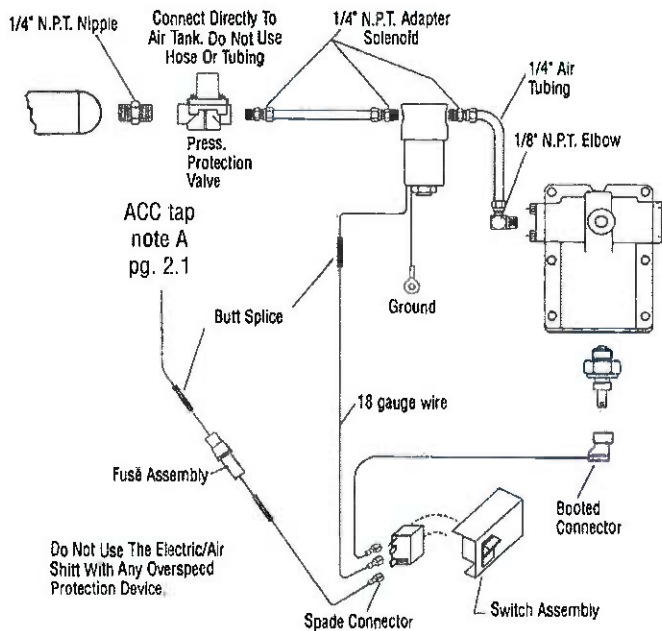

82 SERIES DOUBLE ACTING AIR SHIFT SYSTEM (D OPTION)

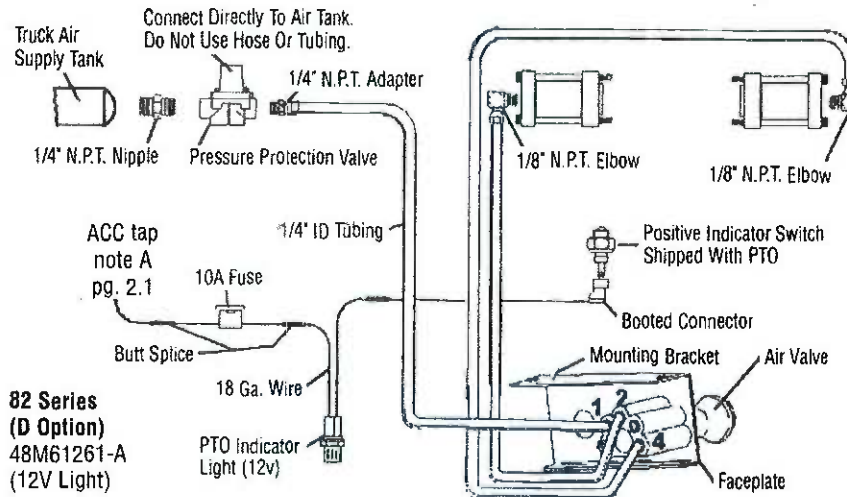

82 SERIES DOUBLE ACTING AIR SHIFT SYSTEM (Q OPTION)

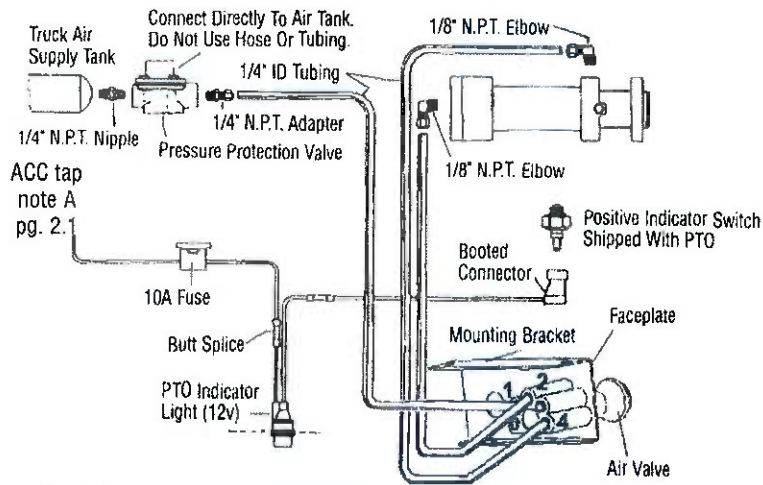

RG, RL SERIES STANDARD AIR SHIFT SYSTEM

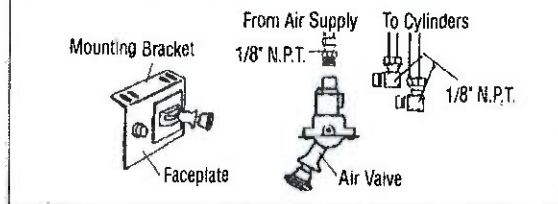

NOTE: Protective Cap For Shift Rail



82 Series (Q Option) 48M61261-A (12V Light) RG, RL Series 48M61260-A (12V Light)

INSTRUCTIONS FOR PUSH/PULL MANUAL AIR VALVE

1. Remove the button cover (5) from the end of the air valve.
2. Using 3/32" allen wrench remove screw (4) from knob.
Hold red knob (3) to loosen screw.
3. Pull the red knob (3) from the valve stem.
4. Unscrew the hex nut (2) from the valve (1).
5. Install the valve (1) through the bracket (6) and face plate (7) using hex nut (2) to hold in place.
6. Place knob (3) over the valve stem, aligning the pin in the groove of the knob (3).
7. Insert screw (4) and tighten with 3/32" allen wrench.
8. Push the button cover (5) onto the knob (3).

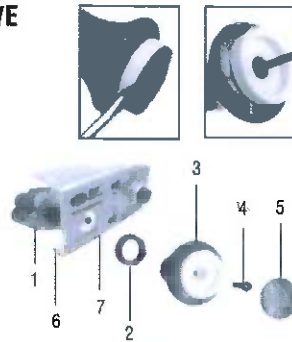

AUTOMATIC TRANSMISSION DIAGRAMS APPLICATION INFORMATION EATON FULLER CEEMAT TRANSMISSIONS

TG, RG, RL, 82 & 83 Series PTOs

Right Side Or Bottom Mount Openings (Not for Engine Driven PTO Opening). Use in addition to the shift system components

Supplied With The PTO.

Eaton Fuller requires the installation of a special wiring harness for PTO indication used in conjunction with their transmission wiring harness. The Muncie add-on kit includes a special indicator switch and wiring harness which is to be wired as shown. Use kit number 48MK1434-14 For TG (1 or 4 assembly), RL, RG, 82 (all assemblies). Use kit number 48MK1434-23 for TG (2 or 3 assembly), and 83 Series PTOs.

For Electric/Air Shift System PTOs use kit number 48MK1435-14 TG Series (1 or 4 assembly) or kit number 48MK1435-23 TG Series (2 or 3 assembly). This kit includes the special indicator switch, wiring harness, indicator light and face plate.

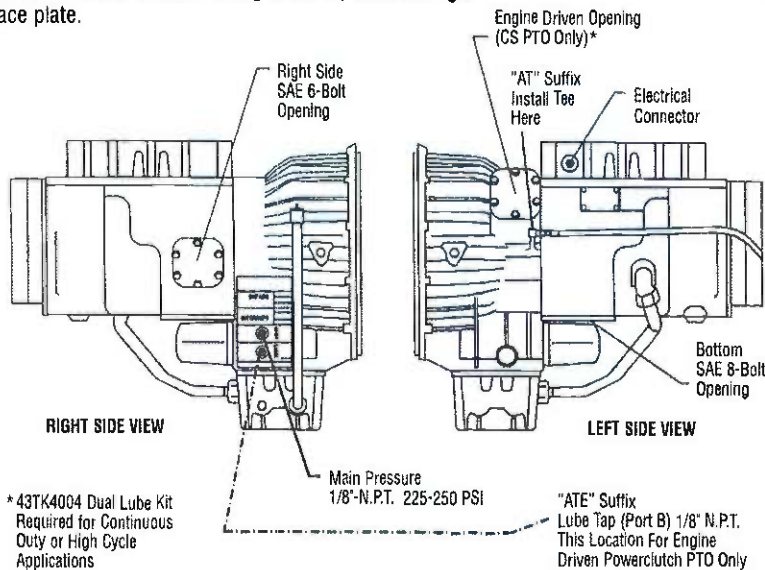
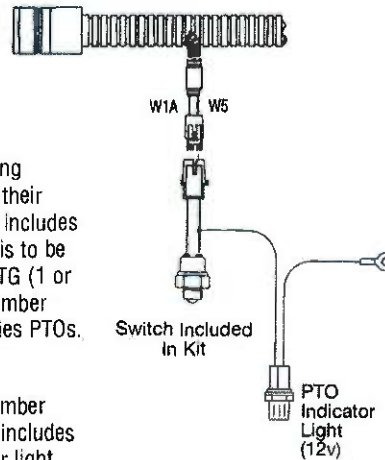

EATON FULLER ULTRA SHIFT

There are two different automated manual transmissions provided by Eaton/Fuller. The Medium Duty 6-speed Ultra Shift and the Heavy Duty 10-speed Ultra Shift. Both transmissions require connection to the transmission control module (TCM) as shown in the diagram. To insure that the vehicle is properly specified for PTO use, contact the chassis dealer. Refer to the Eaton installation manual for specific instructions.

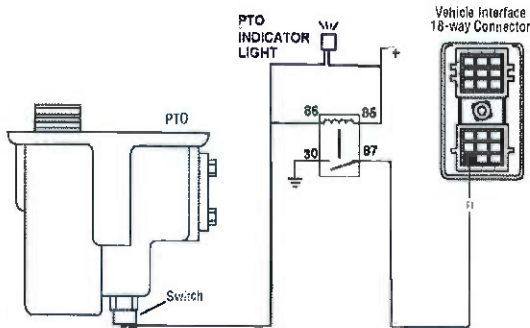

WIRING DIAGRAM FOR EATON/FULLER AUTOMATED MANUAL TRANSMISSIONS

1. Locate wire connected to the #F1 on the 18-way, connector on the transmission control module (middle position).

Chassis dealer or body builder information should be able to help you find this information.

2. If no wire is present, then obtain the Eaton document TRIG-0082 (6 spd. Version) or TRIG-2500 (10 spd. Version).

Review their instructions for obtaining the Packard (Delphi) terminal described in the PTO section of the Eaton document.

3. Muncie recommends the installation be wired as shown by using a standard, Normally Open, automotive relay.

Follow the recommended wiring shown.

Connector DM3 or AW3

Transmission ECU Connector
(Vehicle Interface)

37	29	30	31	32	33	34	38
13	14	15	16	17	18	19	21
35	7	8	9	10	11	12	22
	1	2	3	4	6	6	26

Front View - Terminal #18



JATCO AUTOMATIC TRANSMISSION

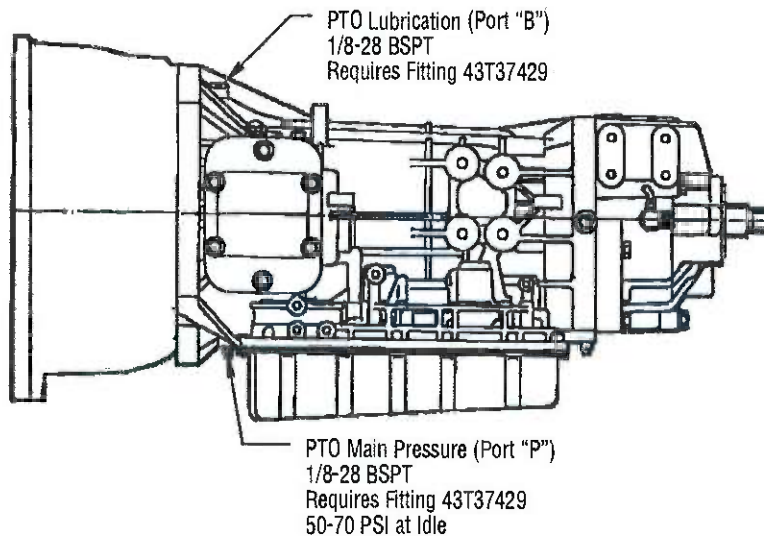

1/8-28 BSPT Requires Fitting 43T37429 50-70 PSI at Idle

**AISIN AUTOMATIC TRANSMISSION
MODELS 450-43LE, A443, A445
5- SPEED**

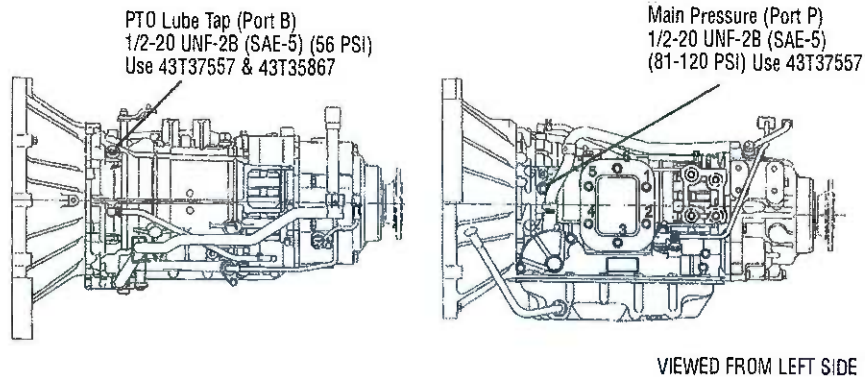

AISIN AUTOMATIC TRANSMISSION 6- SPEED

(For Dodge/Sterling Bullet 2007 and later
using separate instructions IN07-03.)

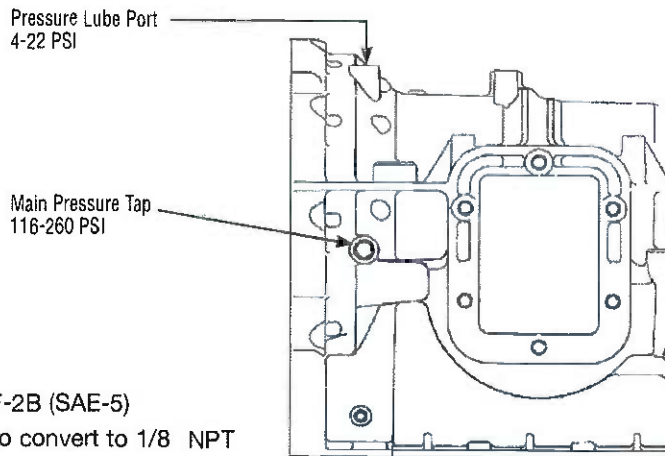

Ports 1/2-20 UNF-2B (SAE-5)
Use 43T37557 to convert to 1/8 NPT

Locate the two pressure ports on the Left side of the Aisin 6-speed automatic transmission.

Connect Main Pressure to port #1 on CS6 solenoid valve as shown in the Electric/Hydraulic Clutch shift instructions.

Connect the pressure lubrication hose the Pressure Lube Port "P" as shown in the Electric/Hydraulic Clutch shift instructions.

AUTOMATIC TRANSMISSION DIAGRAMS APPLICATION INFORMATION

ALLISON TRANSMISSION

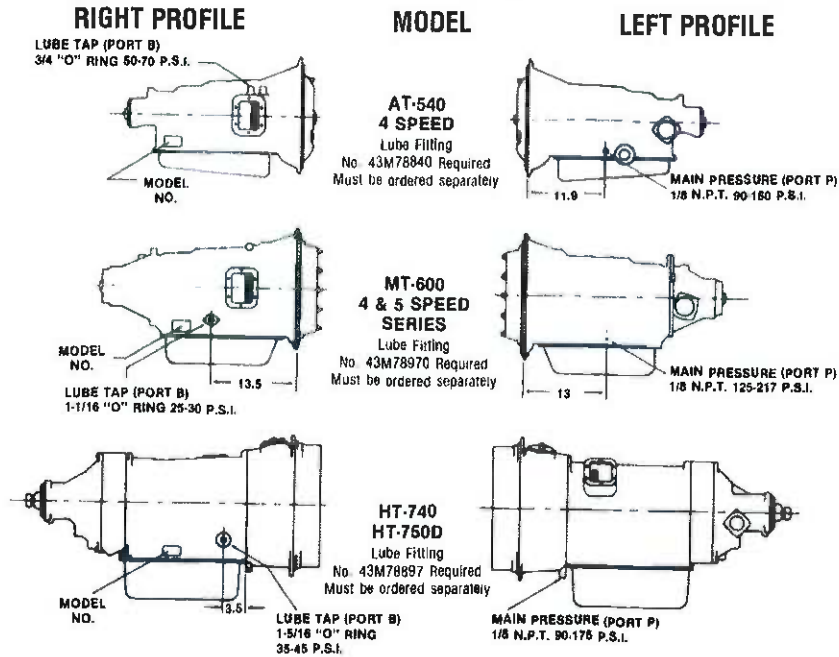

ALLISON AUTOMATIC TRANSMISSION 1000 SERIES™, 2000 SERIES™, AND 2400 SERIES™

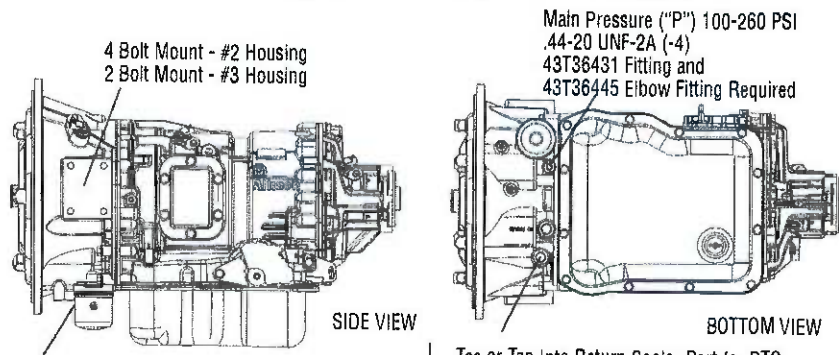

Locate Main Pressure Tap on
Bottom of Transmission Converter

GM (Only) Applications:

Use Lube Tap Kit 43TK4497 on C3500 - C5500 Chassis

Use Lube Tap Kit 43TK4503 on C6500 - C8500 Chassis

On GM3600 Cab Chassis, the cooling lines enter the side of the transmission case, use 43TK4497 for lubrication line installation.

Tee or Tap into Return Cooler Port for PTO
Pressure Lubrication (Where Required)

(SAE-8) 1000 Series (#3 Housing) use 43M78840
Tee Fitting

(SAE-12) 1000 or 2000 Series (#2 Housing) use
43M78970 Tee Fitting

Chassis Info: International, Hino, Mitsubishi -

Remove factory elbow in lubrication return port
and drill and tap 1/8" NPT port. Thoroughly clean
and reinstall chassis lines.

ALLISON AUTOMATIC TRANSMISSION 1000 SERIES™ OR 2000 SERIES™

When using the Allison transmission for stationary operation it is beneficial to engage the torque converter lock-up. This allows for a direct comparison of the output shaft speed to engine speed, without the affects of the torque converter.

Muncie requires an electrical connection to the vehicle TCM terminal J106 (WTEC II) or Pin 43 (Gen IV) reference Allison documentation for PTO enable. This notifies the transmission that a PTO is active and will allow for increased transmission activation pressures and transmission torque converter lock-up.

The Allison automatic transmission special wiring instructions depend on the chassis. Please refer to body builder's manuals and special instructions listed there for connection of Muncie PTOs. It is required that clutch shifted PTOs mounted to the Allison 1000 series or 2000 series be wired to the Allison transmission control. The PTO enable circuitry provided by Allison allows for full PTO output specifications. This means that the PTO enable circuit must be located and connected.

On GM Medium Duty vehicles C/K4500 thru C8500, this accomplished be connecting to the GM PTO control harness. Request documentation for the Muncie wiring harness kits 34TK4504 used for clutch shift PTOs or 34TK4505 used for the TG series PTO.

On Light Duty vehicle C/K3600 request installation kit 48TK4461. Pickup chassis C/K2500 C/K3500 may not have proper electrical connections, contact GM upfitter's group for assistance.

International Truck and Engine Corp. has a specific PTO control which makes the appropriate connection when the correct activation option is ordered with the vehicle. PTO options are specified through the truck chassis dealer.

CS6B, GA6B Series

Depending on the Chassis used connection to the PTO enable terminal can be accomplished be attaching a wire to the switched power from the PTO rocker switch and connecting it to the J106 terminal (WTEC II) or Pin 43 (Gen IV). GM chassis wiring harnesses are available for connection to this circuit requires GM PTO option to be installed.

GM6B Series

Installation of this PTO is described in IN 01-03 and is not contain in this document. This PTO is made for the GM 3600 chassis and comes with wiring which already controls the J106 (WTEC II) or Pin 43 (Gen IV) circuit.

TG Series

Cable, lever, and air shifted PTOs can be install with either a two terminal switch or the use of a standard automotive relay as shown on the diagrams. Diagram 1 or Diagram 2

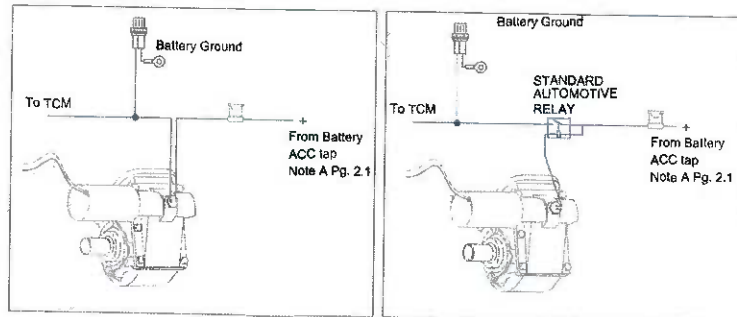

GM THROTTLE ADVANCE C4500 SERIES™ THRU C8500 SERIES™

PTO Upfitter Connector

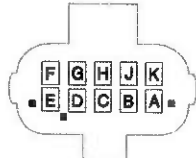

7.2L DIESEL (CAT 3125) VARIES FROM THIS DIAGRAM, BUT MUNCIE CONNECTOR IS CORRECT FOR ALL APPLICATIONS

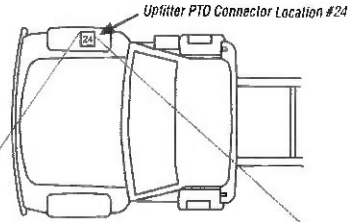

Top View of Truck Cab

Upfitter Wire Chart

PIN	WIRE	
	Ckt #	Color
A	N/C	--
B	494	BLU LT
C	488	GRN LT
D	250	BLK
E	2683	PPL
F	488	GRN LT
G	2522	YEL
H	2561	WHT
J	N/C	--
K	2684	TAN

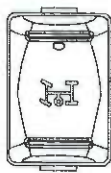

Dash Switch

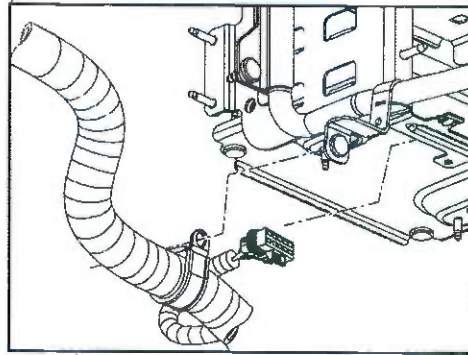

34TK4504 INSTALLATION INSTRUCTIONS FOR CLUTCHSHIFT PTO ONLY

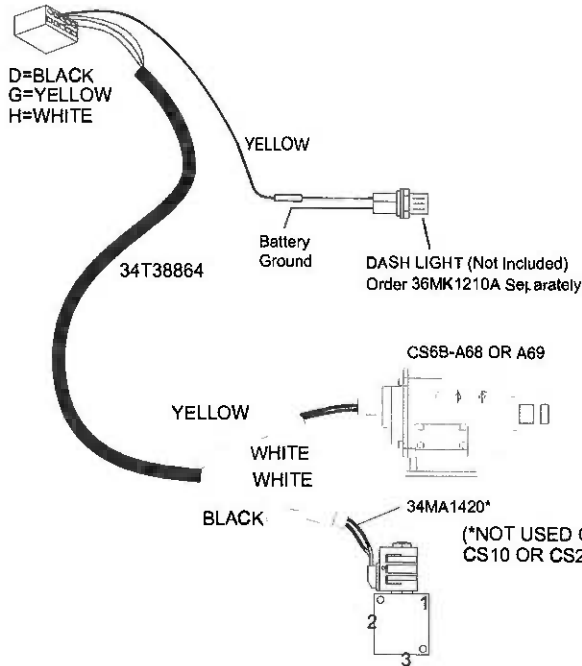

Note: ALLISON CONNECTOR

TRANSMISSION CONNECTOR LOCATED IN SAME AREA AS PTO CONNECTOR, NOT USED.

PIN	WIRE COLOR
A	PURPLE
B	YELLOW
C	YELLOW
D	--
E	--
F	TAN
G	--
H	BLACK
J	BLACK
K	LIGHT BLUE

Follow PTO shifting instructions listed in the PTO Owner's manual for engagement of CS Series PTOs.

For stationary operation with vehicle stopped and transmission gear selection in park, cruise turned "on", foot off accelerator, turn on PTO dash switch.

For "Preset" type throttle control, push Cruise Control set button to increase throttle to the preset speed programmed into the controller. This is 1200 rpm by default.

Advance only works when Cruise Control is on.

More information is available in the General Motors Body Builders manuals available from GM or on their website at www.gmupfitter.com

34TK4505 INSTALLATION INSTRUCTIONS FOR TG SERIES PTO ONLY

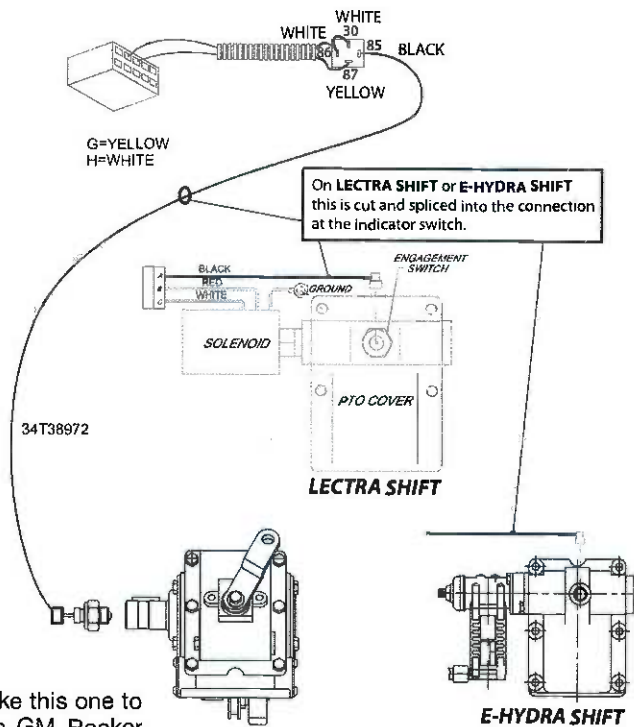

This wiring harness does not allow mechanically shifted PTOs like this one to be activated by the GM Rocker Switch. It will only assist in the engine throttle advance of the application. Install PTO controls separate of the installation.

Follow PTO shifting instructions listed in this PTO owner's manual for engagement of manual shift-type PTOs.

Engage PTO first.

For stationary operation, throttle advance with vehicle stopped and transmission gear selection in Park, parking brake set, foot off accelerator, and turn on PTO Dash Switch.

For "Preset" type throttle control, push Cruise Control set button to increase throttle to the preset speed programmed into the controller. This is 1200rpm by default.

Advance only works when Cruise Control is on.

More information is available in the General Motors Body Builders manuals available from GM or on their website at www.gmupfitter.com.

MERCEDES AGS (AUTOMATED TRANSMISSION)

WARNING: PTOs MOUNTED TO THE MERCEDES AGS TYPE TRANSMISSION WILL NOT FUNCTION UNLESS VEHICLE IS PROPERLY SPECIFIED.

THE MERCEDES AGS SERIES TRANSMISSION REQUIRES THE PTO TO BE INSTALLED THROUGH THE PROVIDED PTO ACTIVATION, AIR SOLENOID CONTROL. THE PTO MUST BE AIR SHIFT OPTION WHETHER IT IS A MECHANICAL TYPE (TG, SH, RS4S SERIES) OR CLUTCH SHIFT (CS6 SERIES) TYPE. THE VEHICLE NEEDS TO BE SPECIFIED FOR PTO USE FROM TIME OF ORDER. CONTACT DEALER FOR PTO CONNECTION LOCATIONS.

CLUTCH SHIFT & SH STANDARD AIR SHIFT SYSTEM

For Use When Air Shifting CLUTCH SHIFT or SH Series PTOs

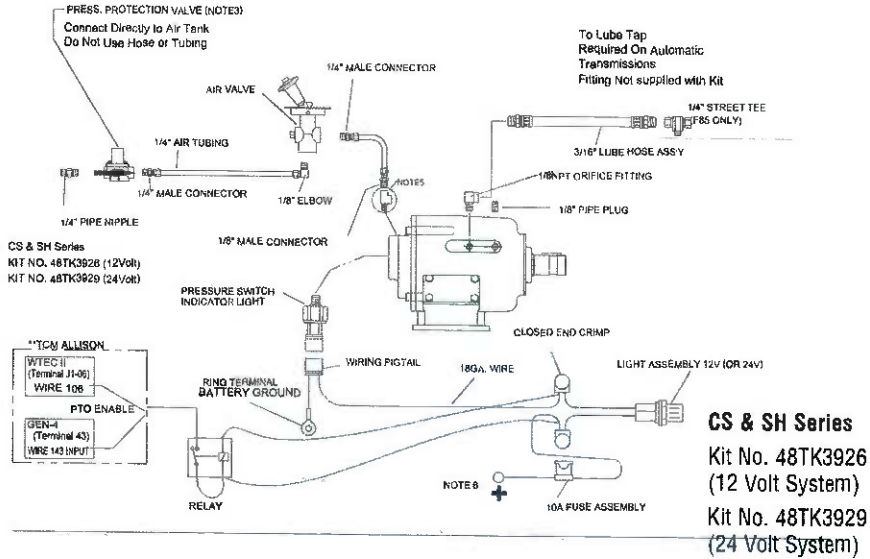

SYSTEM PROTECTION DEVICE

(CS Series Only)

SPD-1000A shown is sold separately.
Refer to IN07-04 when making this installation.

FOOTNOTES

1. Green light in rocker switch is to turn "ON" when PTO is engaged and to turn "OFF" when PTO is disengaged.
2. Solenoid valve should be mounted on firewall to protect it from corrosive environment.
3. Air System Users...You will not receive any air through the pressure protection valve to the PTO system until your main tank pressure exceeds 65 PSI. Some chassis' have dual air systems. Be sure to connect to the MAIN air supply tank or to the connection specified by the vehicle manufacturer.
4. Hydraulic hoses and hose ends not supplied with standard installation kit. Order Muncie 131-2-0001 separately.
5. Street Tee provided for clearance mount of pressure switch or for CS6G installation, be sure to plug unused port(s).
6. Connection to positive battery ACC tap as identified by chassis manufacturer. See note A on pg 2.1.

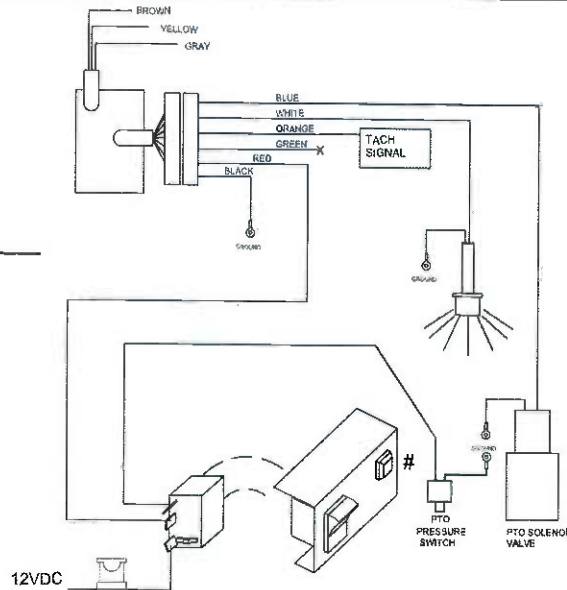

CLUTCH SHIFT ELECTRIC/HYDRAULIC SHIFT SYSTEM

For Hydraulic Shifting CLUTCH SHIFT Series PTO on Automatic Transmissions

On Automatic Transmissions with externally solenoid controlled converter neutral lock-up, install the ClutchShift activation circuit completely separate of the lock-up circuit. Do not use the same valve to operate both circuits.

TO TRANSMISSION MAIN PRESSURE PORT 1"

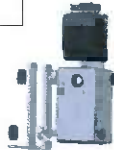
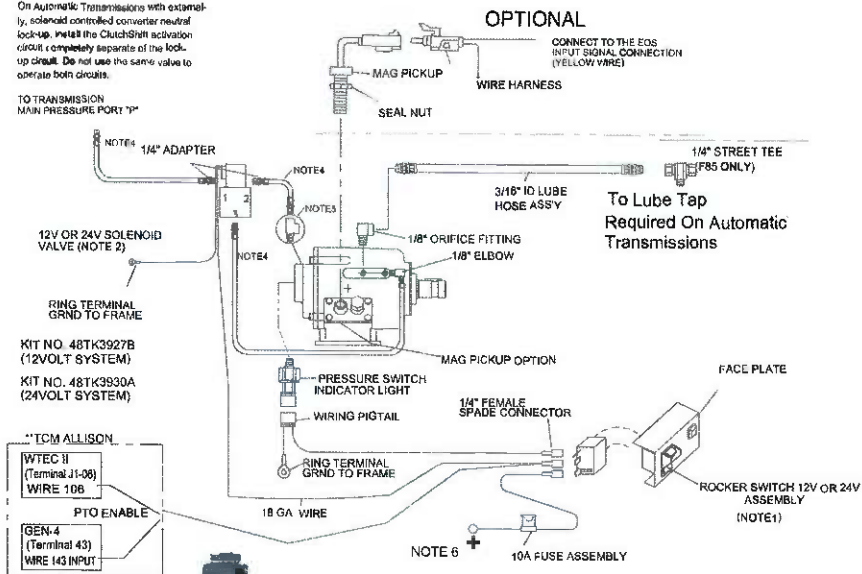

Do not mount solenoid to a flat surface without spacing the block with washers. Damage to valve will occur if coil is allowed to bind against any surfaces.

CLUTCH SHIFT & SH HEAVY ELECTRIC/AIR SHIFT SYSTEM

For Use When Air Shifting CLUTCH SHIFT or SH Series PTOs

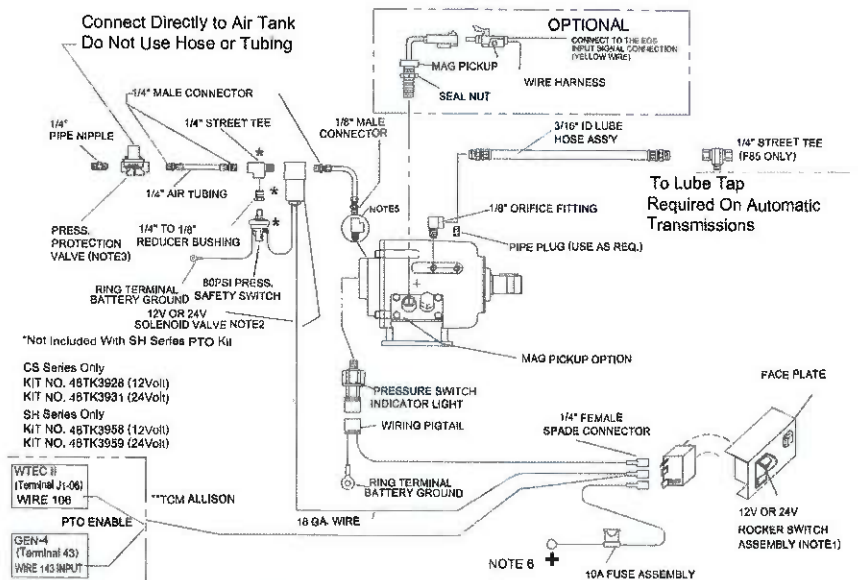

CLUTCH SHIFT INSTRUCTIONS & TESTS

1. Install the appropriate shifter kit components described on pages 2.11 - 2.16. On Allison, Aisin, Eaton Fuller CEEMAT and JATCO Automatic installations be sure that the lube orifice fitting is installed in the housing port as shown on 1. Use only the fitting supplied with your kit to assure proper transmission function.

Allison transmissions with neutral lock-up should be installed on a circuit separate of PTO shift circuit. The circuits are supplied by the transmission main pressure and should be teed together at, and closest to, the main pressure port (port P) as shown on diagrams found on pages 2.11 thru 2.17

2. With ignition switch on (but engine not running) turn on the PTO control switch and listen for solenoid valve. You should be able to hear valve snap open. If not, check for a poor ground connection. The ground must be a bare metal contact to frame.

3. Start engine and engage PTO with switch. If PTO fails to operate or will not develop enough torque to operate your equipment, check pressures as follows:

a. Stop engine.

- b. Install 400 PSI pressure gauge at PTO piston port. (Fig. A) (150 PSI gauge for air systems).

- c. Install a second 400 PSI pressure gauge in front of screen adapter at solenoid valve. (Fig. B) (150 PSI gauge for air systems).

- d. Start engine. Stay clear of rotating components. Place PTO switch in engage position.

- e. If either gauge registers less than 90 PSI, or if there is more than 50 PSI difference at any engine speed, check for obstructions in the hoses or the screen adapter.

- f. On the hydraulic system if gauge (Fig. B) registers 50 PSI or less, you may be connected to the wrong port on the transmission. Recheck the transmission information for the main pressure tap location on your model.

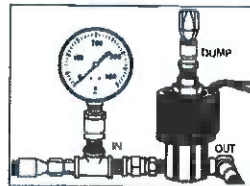
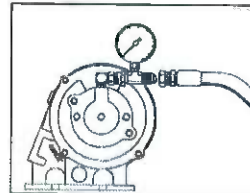

4. Complete installation by placing warning labels as indicated on borders of the decals. Placement examples are illustrated on pages 1.1 and 1.2.

Upon installation, the Clutch Shift output shaft may operate in the off position. If this occurs, double check plumbing for restrictions in the lines. If OK, adjustment of the drag brake may be required. Clutch Shift requires a minimal load on the output shaft.

The CS6 & CS8 PTO is equipped with an internal drag brake as standard. The brake is adjustable, should the output shaft continue to turn once PTO is disengaged.

Note: This brake will **not** stop shaft if there is a catastrophic failure with PTO clutch pack. See Section 3 for more information.

Drag Brake Adjustment Procedure:

1. Stop engine.

2. Locate adjustment screws on the end cover per the diagram.

3. Using 3/16" Allen wrench turn each of the set screws 1/4 turn clockwise.

4. Move away from under the vehicle and away from possible moving components and restart the engine. Look for the output shaft to stop turning. If the shaft continues, then **shut the engine off** and repeat steps 2 thru 4.

For U60, F85, I84 & I85 PTOs install 1 spring per hole in these 2 holes. No springs in other holes. (Mark these 2 screws with red paint.)

For all other ratios install 1 spring per hole in all 4 holes. (Do not paint these screws.)



COVER END VIEW

SECTION 3 OWNER'S MANUAL

POWER TAKE-OFF WARRANTY

The Muncie Power Take-Off is warranted to be free of defects in material or workmanship and to meet Muncie's standard written specifications at the time of sale. Muncie's obligation and liability under this warranty is expressly limited to repairing or replacing, at Muncie's option, within one year after date of original installation any defective part or parts or any product not meeting the specifications.





THIS WARRANTY IS IN LIEU OF ALL OTHER WARRANTIES, EXPRESSED OR IMPLIED. MUNCIE MAKES NO WARRANTY OF MERCHANTABILITY OR OF FITNESS FOR ANY PARTICULAR PURPOSE. MUNCIE'S OBLIGATION UNDER THIS WARRANTY SHALL NOT INCLUDE ANY TRANSPORTATION CHARGES OR COSTS OF INSTALLATION OR ANY LIABILITY FOR DIRECT, INDIRECT SPECIAL, INCIDENTAL, OR CONSEQUENTIAL DAMAGES OR DELAY. THE REMEDIES SET FORTH HEREIN ARE EXCLUSIVE, AND MUNCIE'S LIABILITY WITH RESPECT TO ANY CONTRACT OR SALE OR ANYTHING DONE IN CONNECTION THEREWITH, WHETHER IN CONTRACT, IN TORT, UNDER ANY WARRANTY, OR OTHERWISE, SHALL NOT, EXCEPT AS EXPRESSLY PROVIDED HEREIN, EXCEED THE PRICE OF THE PRODUCT OR PART ON WHICH SUCH LIABILITY IS BASED.

If requested by Muncie, products or parts for which a warranty claim is made are to be returned transportation prepaid to a Muncie Service Center. Any installation or use not in accordance with catalogue or package instructions, other improper use, operation beyond capacity, substitution of parts not approved by Muncie, use with equipment other than the equipment on which the Power Take-Off is first installed, or alteration or repair made to the Power Take-Off other than at a Muncie Service Center shall void this warranty. No employee or representative of Muncie is authorized to change this warranty in any way or to grant any other warranty.



PTO SHIFTING PROCEDURE & PRECAUTIONS

POWER TAKE-OFF OPERATION - VEHICLE STATIONARY

-  **WARNING - PARKING BRAKE MUST ALWAYS BE SET**
-  **WARNING - VEHICLE'S WHEELS MUST ALWAYS BE CHOCKED**
-  **WARNING - TRANSMISSION MUST ALWAYS BE IN NEUTRAL OR PARK**
-  **WARNING - AN OPERATOR MUST ALWAYS BE IN THE DRIVER'S SEAT WHENEVER THE ENGINE IS RUNNING AND THE TRANSMISSION IS IN GEAR, IN ORDER TO PREVENT OR STOP ANY UNEXPECTED MOVEMENT OF THE VEHICLE WHICH MAY CAUSE INJURIES TO THE OPERATOR OR OTHERS IN THE VICINITY.**

- **READ ALL OPERATORS MANUALS AND INSTRUCTIONS FOR THE EQUIPMENT THAT YOU ARE OPERATING ON THIS VEHICLE.**
- **OBTAIN INSTRUCTIONS AND TRAINING FOR ALL OPERATIONS OF THE EQUIPMENT ON THIS VEHICLE INCLUDING THOSE NOT COVERED BY THIS INSTRUCTION BOOKLET.**
- **NEVER WORK ALONE WHEN REPAIRING OR GOING UNDER A VEHICLE FOR REPAIR OR MAINTENANCE.**
- **ALWAYS BLOCK ANY RAISED OR MOVEABLE COMPONENTS OR DEVICES WHEN WORKING ON OR AROUND THE VEHICLE AS SPECIFIED BY THE EQUIPMENT MANUFACTURER.**
- **WARNING: PTOS MAY DRIVE DRIVEN EQUIPMENT WITH AN EXPOSED DRIVE SHAFT WHICH MAY CAUSE SEVERE INJURY OR DEATH IF CONTACTED.**
- **CARE MUST BE TAKEN WHEN USING A PTO FOR ANY SPECIFIC APPLICATION THAT THE PTO HAS BEEN PROPERLY SPECIFIED TO MATCH THE TRANSMISSION AND AUXILIARY EQUIPMENT. IMPROPER SPECIFICATION AND INSTALLATION CAN CAUSE SEVERE DAMAGE TO THE VEHICLE TRANSMISSION AND THE AUXILIARY COMPONENTS INCLUDING DRIVESHAFTS AND DRIVEN EQUIPMENT. DAMAGED COMPONENTS, EQUIPMENT RESULTING IN FAILURE CAN CAUSE SERIOUS PERSONAL INJURY TO OPERATORS AND PERSONS IN THE VICINITY.**
- **ALWAYS FOLLOW RECOMMENDED PROCEDURES FOR SELECTING, INSTALLING, OPERATING, OR REPAIRING A POWER TAKE OFF AS FOUND IN MUNCIE OWNER'S MANUALS, SERVICE PARTS LISTS AND SERVICE MANUALS, CATALOGS, AND APPLICATION GUIDES.**
- **NEVER USE A MUNCIE PTO ABOVE THE RECOMMENDED OPERATING SPEED OF THE UNIT OR THE SPECIFIED DRIVEN UNIT.**
- **NEVER USE A POWER TAKE OFF THAT HAS NOT BEEN SPECIFIED FOR THE OUTPUT CAPABILITIES FOR THE EQUIPMENT BEING DRIVEN.**

ROTATING PTO DRIVE SHAFTS

IT IS RECOMMENDED THAT DIRECT COUPLE HYDRAULIC PUMPS BE USED WHENEVER POSSIBLE, BUT IF YOUR APPLICATION REQUIRES THE USE OF AN EXPOSED DRIVE SHAFT IT IS THE RESPONSIBILITY OF THE INSTALLER AND PURCHASER TO DETERMINE THE BEST INSTALLATION OF A GUARD.

- **ROTATING SHAFT CAN SNAG CLOTHING, SKIN, HANDS, HAIR, ETC. AND WILL CAUSE SERIOUS INJURY OR DEATH.**

- DO NOT GO UNDER THE VEHICLE WHEN THE ENGINE IS RUNNING.
- DO NOT WORK NEAR AN EXPOSED DRIVE SHAFT WITH ENGINE RUNNING.
- AUXILIARY SHAFT CAN BE INSTALLED WITH RECESSED OR PROTRUDING SET SCREWS. IF RAISED, SQUARE HEAD SET SCREWS ARE CHOSEN, THEN BE AWARE THAT THIS IS A CATCH POINT FOR CLOTHES, SKIN, HAIR, HANDS, ETC. AND SERIOUS INJURY OR DEATH MAY RESULT.

 THE OUTPUT SHAFT OF A PTO WITH INTERNAL CLUTCH PACKS MAY ROTATE IN COLD TEMPERATURES WITH THE PTO DISENGAGED. PTO SHAFT ROTATION CAN CAUSE SUDDEN MOVEMENT OF THE OUTPUT SHAFT AND ATTACHED DRIVE SHAFT LEADING TO PERSONAL INJURY OR DEATH. ALLOW TRANSMISSION TO OPERATE FOR A FEW MINUTES BEFORE ENGAGING PTO. ALLOW PTO TO OPERATE FOR A FEW MINUTES BEFORE ACTUATING APPLICATION CONTROLS.

SOME O.E.M. CHASSIS MANUFACTURERS HAVE INTEGRATED ELECTRONIC CONTROLS WHICH REQUIRE CERTAIN CONDITIONS TO BE MET BEFORE ENGAGING A PTO. THESE INCLUDE, BUT ARE NOT LIMITED TO SETTING PARKING BRAKE, FOOT OFF SERVICE BRAKE, ENGINE AT IDLE, FOOT OFF ACCELERATOR PEDAL, AND/OR TRANSMISSION SELECTOR IN PARK OR NEUTRAL.

1. Mechanical Transmission

- A. A power take-off is, and should be, operated as an integral part of the main transmission.
- B. Before shifting the Power Take-Off into or out of gear disengage the clutch and wait for transmission or PTO gears to stop rotating.

2. Automatic Transmission with Manual Shift PTOs (includes Air Shift)

— Manual Shift PTOs include SG, TG, SH, RL, RG, RX, 82, 83 Series PTOs
 — On automatic transmissions, the gears in the transmission turn when the transmission is in neutral, therefore, gear clashing will occur if the power take-off is shifted *into gear (engaged)* or *out of gear (disengaged)* at this time.
With Converter Driven Gear:

- A. Engine idle. With the operator seated in the driver's seat and while activating the vehicle's brake, shift transmission lever into any of the drive positions. (This will stop transmission gear from turning.)
- B. Shift power take-off into or out of gear.
- C. If the PTO does not engage release the PTO to the disengage position, shift the transmission to neutral and repeat the above steps from step A.
- D. Shift transmission into park or neutral. (This will start transmission gears turning.) If you hear a grinding or ratcheting sound turn PTO off and repeat these procedures from step A.

3. Automatic Transmission/Transfer Case Mounted PTO (Also SS66 Splitshaft PTO)

- A. Shift transmission into park.
- B. **Caution: Apply parking brake and block wheels. Note: Applying parking brake does not insure that vehicle will not move when transfer case is in neutral.**
- C. Engage PTO.

- D. Shift transfer case into neutral.
- E. Shift transmission into drive to activate PTO output shaft. Caution: Do not place the transmission selector in park or reverse while PTO is operational as damage to PTO or driven unit may occur.

To Disengage PTO:

- F. **Shut off** engine with transmission in drive mode.
- G. Disengage PTO.
- H. Shift transmission selector to park.
- I. Restart engine.
- J. Remove wheel blocks and release parking brake.
- K. Shift transfer case into engaged mode.
- L. Vehicle can now be driven.

Failure to follow proper shifting or operating sequences will result in premature PTO failure with possible damage to the equipment.

CLUTCH SHIFT OPERATING NOTES

CLUTCH SHIFT PTOs should not be engaged (turned "ON") under heavy load and/or at engine speeds over 1200 RPM. If your operators are careless or negligent in this respect, you can safeguard your equipment with one or more Muncie protective systems.

Consult your Muncie product literature or call your nearest Muncie Power Center for information on the SPD-1000A System Protection Device which prevents engagement of your CLUTCH SHIFT PTO above safe speeds.

The red overspeed light on the PTO control switch panel is for use with the SPD-1000A and will indicate an overspeed condition when wired according to instructions in the SPD-1000A Installation Manual.

Upon installation, CLUTCH SHIFT output shaft may rotate while in the off position. If this occurs, recheck plumbing for restrictions in the lines. If the plumbing is okay, adjustment of drag brake will be required. The Clutch Shift requires a minimal load on the output shaft. See your PTO installer or refer to page 2.20 for adjustment instructions. The CB Series does not require adjustment.

PTO MAINTENANCE

The Power Take-Off, being an integral part of the transmission, should be serviced at the same intervals as the transmission. Transmission fluid changes should follow the interval recommended by the vehicle manufacturer for severe service. Transmission oil level is important. Checking for PTO leaks and checking the transmission oil level should be done on a regular basis.

Check for leaks upon delivery of the vehicle and after initial operation of your equipment. Loss of any oil can significantly affect or damage a transmission or PTO. Muncie Power Products, Inc. is not responsible for damage resulting from improper fastener installation, mounting torque or maintenance of the PTO.

The Power Take-Off is also part of a system. The PTO system may include the activation control parts, a driveshaft, or hydraulic pump. This PTO system requires periodic checks and service. Typically the interval for maintenance checks of the PTO system depends on the application of the system. Every time the chassis is lubricated or a mechanic is under the vehicle the PTO system should be checked and serviced. For severe duty PTO system applications, it is recommended that the system be checked for service every 100 hours of use (this guideline can be adjusted based on past

service history once you have it established). Service should include checking and lubricating direct mount pump shaft connections. PTO gears can be checked for wear by removing the inspection or shifter cover. If pitting, galling, cracking, or deformation of the gears or splines has occurred, then the PTO needs to be rebuilt or replaced.

Within the first week of use, recheck the installation of the PTO. Check for leaks and loose mounting hardware (studs, cap screws, nuts). Recheck the cable or lever connections for proper adjustment and tighten any loose connections. At regular maintenance intervals, check adjustments and lubricate moving parts, tighten and repair the connections, mounting hardware, cable or lever linkages.

It is recommended that the operator/owner do a visual inspection for leaks under and around the vehicle and equipment on at least a weekly basis. Any leaks found should be corrected immediately.

Pumps that are mounted directly to the PTO output require the application of an anti-seize or a high temperature, high pressure grease. (Muncie PTOs are initially supplied with the required grease.) The purpose of this grease is to help make the PTO easier to service and to reduce the effects of fretting corrosion on the mating PTO and pump shafts. PTO applications under severe duty cycles and/or high torque requirements may require servicing this shaft connection by periodically re-greasing the shafts. Vehicles with low speed diesel engines are also severe applications due to the vibrations inherent in these vehicles. Fretting corrosion cannot be stopped by applying grease, the grease is only a deterrent.

INDICATOR LIGHT CHECK



Procedure for checking the PTO Indicator Switch is found on Page 2.7

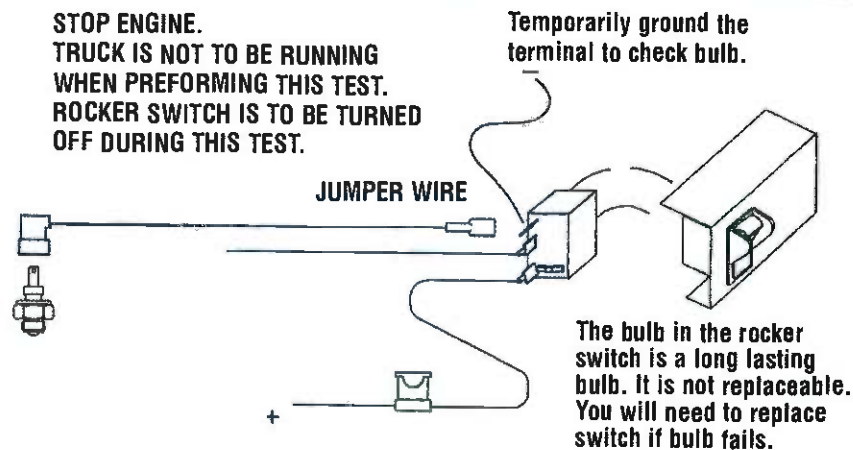
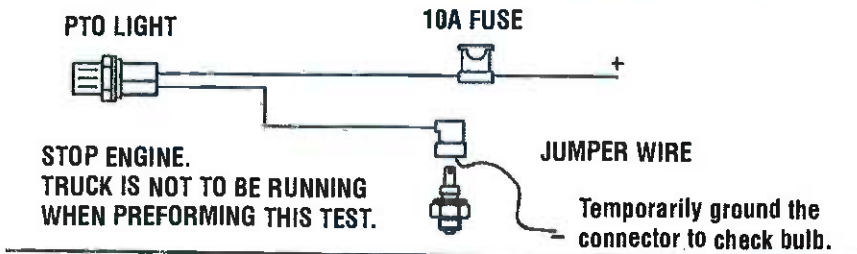

PTO TORQUE & HORSEPOWER RATINGS

Intermittent service refers to an On-Off operation under load. If maximum horsepower and/or torque is used for extended periods of time, (5 minutes or more) this is considered "Continuous Service" and the horsepower rating of the PTO should be reduced by multiplying the value below by .70.

PTO SERIES	SPEED RATIO	INTERMIT. HP@1000 RPM	INTERMIT. KW@1000 RPM	TORQUE LBS.FT.	TORQUE NM	MAX. SPEED
SG	10	25	18.6	130	176	2500
TG	04	54	40.3	285	386	2500
	05	51	38	270	366	2500
	06	47	35	245	332	2500
	07	44	32.8	230	312	2500
	08	44	32.8	230	312	2500
	09	39	29	205	278	2500
	12H	40	29.8	210	285	2500
	13H	40	29.8	210	285	2500
	15H	37	27.6	195	264	2500
SH	18H	33	24.6	175	237	2500
	05	76	57	400	542	2500
	07	76	57	400	542	2500
	09	71	53	375	508	2500
	12	62	46	325	441	2500
CS	13	62	46	325	441	2500
	03	57	42.5	300	407	2500
	04	57	42.5	300	407	2500
	05	57	42.5	300	407	2500
	06	57	42.5	300	407	2500
	07	57	42.5	300	407	2500
	09	52	38.8	275	373	2500
	12	52	38.8	275	373	2500
RG	14	52	38.8	275	373	2500
	13	26	19.4	140	190	2500
RL	03	38	28.3	200	271	2500
	05	38	28.3	200	271	2500
RX	ALL	26	19.4	140	190	2500
82	05	95	70.8	500	678	2500
	08	85	63.4	450	610	2500
	09	78	58.2	410	556	2500
	10	78	58.2	410	556	2500
	12	71	52.9	375	508	2500
	13	71	52.9	375	508	2500
	15	67	49.9	350	475	2500
	19	57	42.5	300	407	2500
83	05	95	70.8	500	678	2500
	06	95	70.8	500	678	2500
	12	71	52.9	375	508	2500

PTO TROUBLESHOOTING GUIDE

PROBLEM	POSSIBLE CAUSE	REMEDY	PREVENTION
CABLE SHIFT PTOS			
Hard Shifting	Cable inner member frozen	Thaw in garage	Route cable away from road spray and seal end from moisture
	Sharp bend in cable	Straighten inner member or replace cable	Keep bends larger than the minimum bend radius. Avoid short cable runs
	Improper shifting	Make sure vehicle clutch is adjusted to allow the PTO drive gear to stop before shifting or that the proper shift procedure is followed	See Section 3.
	Worn or damaged shift control	Repair or replace components	Do not connect lever rods to cable shifters
Delayed or partial engagement	Loose linkage or attachment. Loose or missing cable clamps	Repair or replace	Routine maintenance
AIR SHIFT PTOS			
PTO doesn't engage	Contaminated air lines	Remove contaminants from air cylinder	Bleed air system more often
	Air pressure not high enough	Wait until system pressure is above 65 psi before engaging PTO	Systems are designed with a pressure protection valve which does not allow air to the PTO until the system pressure exceeds 65 psi
	Improper method of shifting causing damage to the PTO shift collar	Make sure vehicle clutch is adjusted to allow the PTO drive gear to stop before shifting or that the proper shift procedure is followed	See Section 3.
	Worn or damaged shift control	Repair or replace components	
	Shift fork is out of shift collar	Reassemble onto PTO correctly.	
PTO doesn't disengage	Faulty air valve	Repair or replace	Usually a result of contamination or dirty valve. Keep air system bled and valves free of dirt
	Worn or damaged shift control	Repair or replace components	
	Shift fork is out of shift collar	Reassemble onto PTO correctly.	

PTO TROUBLESHOOTING GUIDE *Continued*

PROBLEM	POSSIBLE CAUSE	REMEDY	PREVENTION
LECTRA SHIFT PTOS			
PTO doesn't engage	Loose connection	Review wiring diagrams in Section 2	Make sure wires are properly supported and connections are properly made
	Poor/improper grounding of electrical circuit	Make all grounds to the vehicle battery	Control module is very sensitive to proper ground
	Blown fuse	Replace fuse with proper rating	Make proper connections
	Improper shifting	Make sure vehicle clutch is adjusted to allow the PTO drive gear to stop before shifting or that the proper shift procedure is followed	See Section 3
	Worn or damaged shift control	Repair or replace components	
CLUTCH SHIFT PTOS			
PTO doesn't engage	Contaminated air lines	Remove contaminants from air cylinder	Bleed air system more often
	Air pressure not high enough	Wait until system pressure is above 65 psi before engaging PTO or 80 psi for the Electric/Air system.	Electric/Air systems are designed with a pressure protection switch which does not allow current to the PTO valve until system pressure exceeds 80 psi
	Air lines are too long	Re-route lines directly to air tanks	Follow installation diagrams
	Hydraulic line connected to wrong port	Review installation diagrams in Section 2	
	Burned or extremely worn clutch pack	Replace worn components	
	Engine RPM too high (SPD)	Adjust SPD per IN07-04	
PTO doesn't disengage	Hydraulic or air lines connected to wrong ports on valve control	Re-route lines	Refer to installation diagrams in Section 2
	Faulty air or hydraulic valve	Repair or replace	Sometimes a result of contamination or dirty valve. Keep air system bled and valves free of dirt
	Burned or extremely worn clutch pack	Repair or replace components	Follow proper engagement procedures in Section 3.
	Misadjusted drag brake	Adjust brake with adjustment screws, see Section 2.	



TG SERIES PTO

PARTS LIST AND SERVICE MANUAL

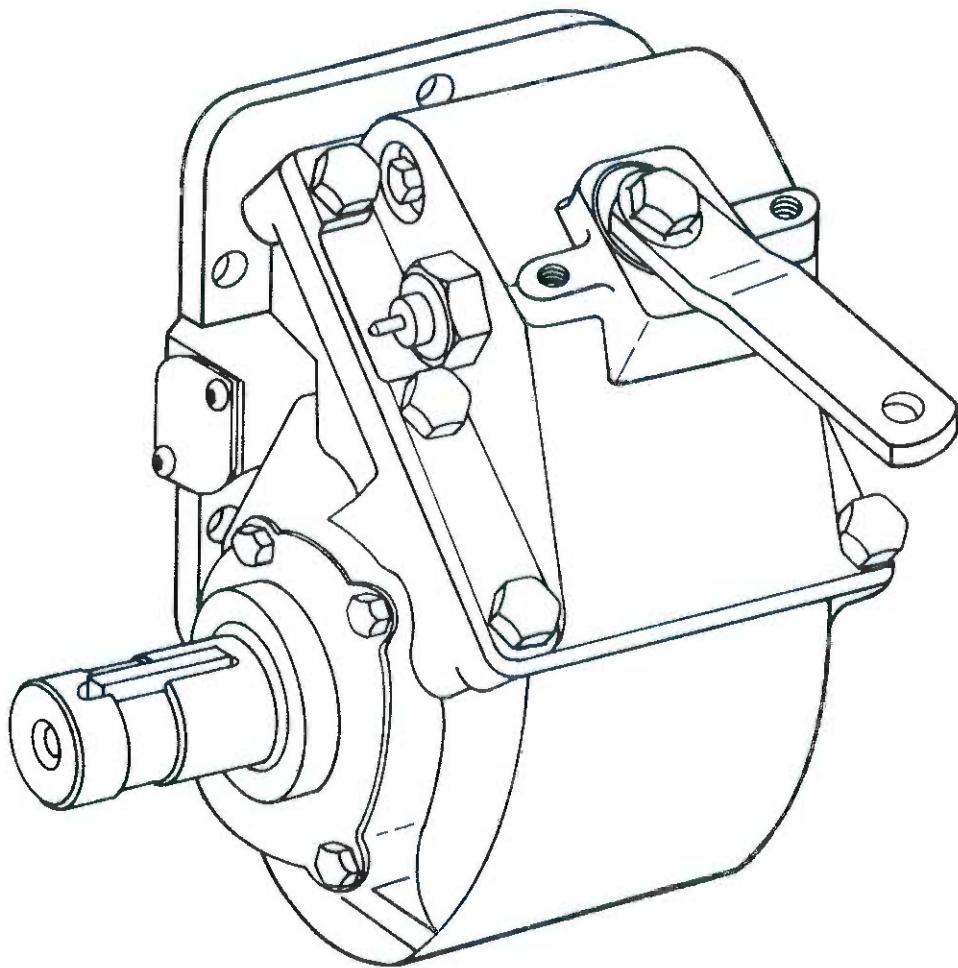

Muncie Power Products, Inc.

TG SERIES PTO EXPLODED VIEW

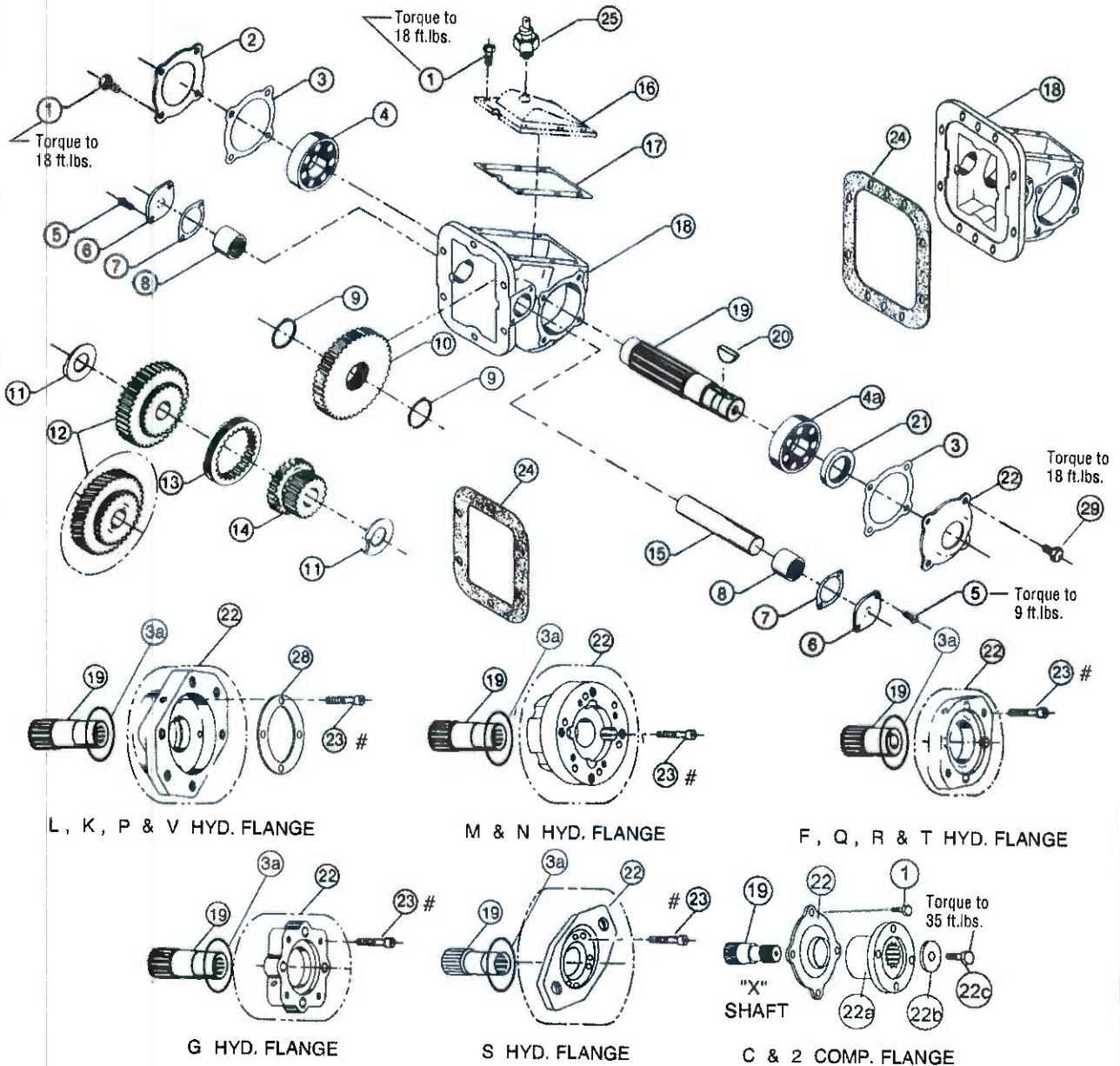

Torque to 25 ft.lbs. Note: For "I" and "Z" options, and "KG" and "PG" options, see page 14.

ASSEMBLY ARRANGEMENTS

