

HYDRAULIC SYSTEM DIAGRAM

FIG 1

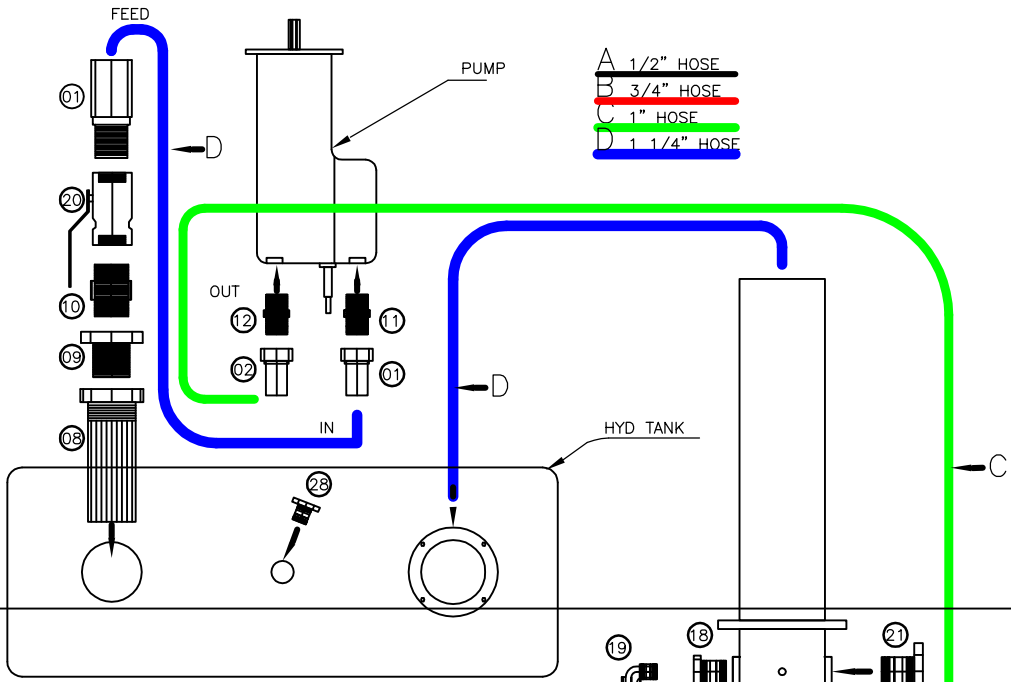

FIG 2

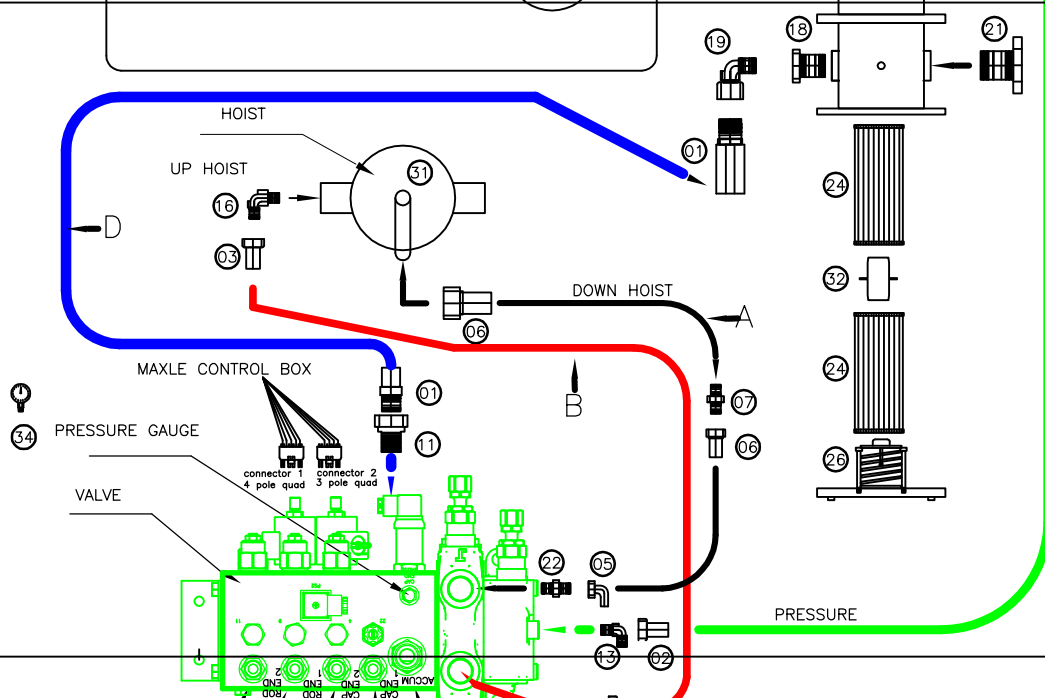
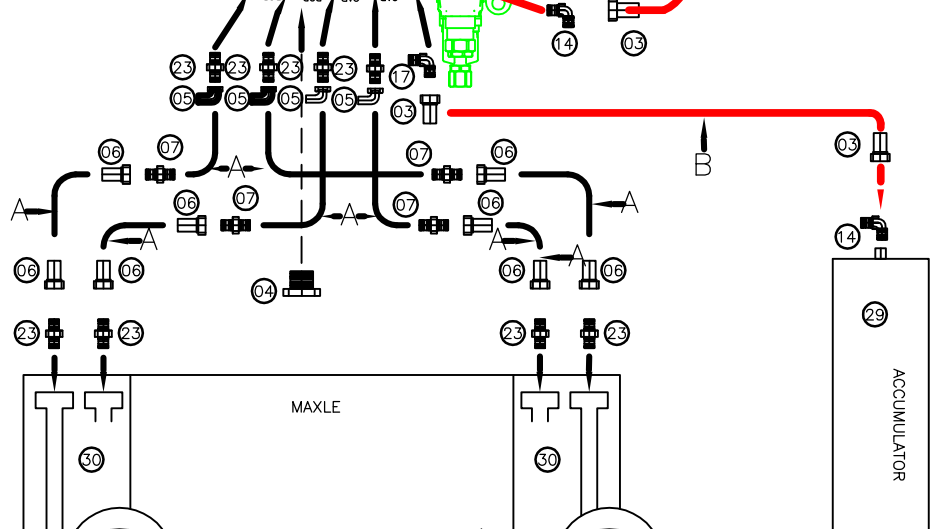

FIG 3



DATE 05/17/10

PART NUMBER	x		
PART NAME	x		
MATERIAL	x		
REVISION #		DATE:	BY.
REVISION #		DATE:	BY.
REVISION #		DATE:	BY.



ROGUE TRUCK BODY LLC.
240 FINCH RD KERBY OR 97531
(541) 592 6972 FAX (541) 592 2527

THIS DRAWING IS THE PROPERTY OF ROGUE TRUCK BODY LLC. AND CONTAINS PROPRIETARY INFORMATION, AND IS NOT TO BE REPRODUCED COPIED OR DISCLOSED, IT IS NOT TO BE USED IN WHOLE OR IN PART TO ASSIST IN MAKING OR FURNISHING INFORMATION FOR THE MAKING OF DRAWINGS, PRINTS, EQUIPMENT OR PARTS THEREFROM EXCEPT IN ACCORDANCE WITH THE EXPRESS WRITTEN CONSENT OF ROGUE TRUCK BODY LLC.

ERROR: syntaxerror
OFFENDING COMMAND: --nostringval--

STACK:

/Title
()
/Subject
(D:20100819105724-07'00')
/ModDate
()
/Keywords
(PDFCreator Version 0.9.5)
/Creator
(D:20100819105724-07'00')
/CreationDate
(gregorio)
/Author
-mark-